

## BIO 201 Mendelian Genetics Practice Problems

**NOTE: Show crosses where ever necessary.**

- In a certain species of plants, purple flowers are dominant to white. When a particular purple-flowered plant is self-fertilized, the progeny are 28 purple-flowered and 11-white flowered. **This ratio is close to 3:1. Therefore, one locus is involved. Let the locus be P locus with P as dominant (purple) and p (white) as recessive alleles.**

(a) What is the genotype of the plant that was selfed? **Heterozygote. Pp X Pp. This gives progeny of the type PP (1): Pp (2) : pp (1). AA and Aa will have the same phenotype as P is dominant over p.**

**That is how we can end up with a 3:1 phenotypic ratio among the progeny of the cross.**

(b) What proportion of the purple-flowered progeny is expected to be true-breeding (pure-breeding, also called “breed true”)? **One third (PP). The others will be heterozygotes (Pp).**

(c) What proportion of the white-flowered progeny will breed true? **All of them will be true breeding. This is because, an individual has to be pp to show white character.**
- Suppose that in a plant species, spiny pods (S) are dominant to smooth (s). Additionally, Purple flowers (P) are dominant to white flowers (p). Consider pod shape and flower color together. What mix of phenotypes would you expect in each of the following crosses? State your assumption(s).

**Assumption: Independent assortment.**

a. **PP ss x pp SS All will be Purple Spiny**

b. **Pp SS x pp ss 50% Purple spiny and 50% white spiny**

c. **Pp Ss x Pp SS 75% Purple spiny and 25% white spiny**

d. **Pp Ss x Pp ss (3/8) Purple spiny; (3/8) Purple smooth; (1/8) White spiny; (1/8) white smooth**

**Explanation: In the given cross, the probability of getting purple progeny is 3/4 and the probability of getting white progeny is 1/4. Similarly, probabilities of spiny and smooth are 1/2 each.**

e. **Pp Ss x Pp Ss**  
**This is a typical dihybrid F2 cross. Therefore, the progeny phenotypes will be Purple spiny (9/16); purple smooth (3/16); white spiny (3/16); white smooth (1/16)**

f. **Pp Ss x pp ss**  
**This is a typical dihybrid F2 Test cross. Therefore, the progeny phenotypes will be Purple spiny (1/4); purple smooth (1/4); white spiny (1/4); white smooth (1/4)**
- Consider the plant species mentioned in question (2). Suppose that a pure breeding Spiny, purple plant is crossed with a pure breeding smooth, white plant.

(a) What will be the phenotype of F1 **(All Purple spiny)** and F2 **(Purple spiny (9/16); purple smooth (3/16); white spiny (3/16); white smooth (1/16))**?

(b) What will be the phenotypes of the progeny from a cross between the F1 and the Purple, spiny parent? **All purple spiny**

(c) What will be the phenotypes of the progeny from a cross between the F1 and the smooth, white parent?

*This is a typical dihybrid F2 Test cross. Therefore, the progeny phenotypes will be Purple spiny (1/4); purple smooth (1/4); white spiny (1/4); white smooth (1/4)*

(d) In the F2 generation, what proportion of the progeny will be homozygous for dominant alleles at both loci? (F1 plant are PpSs. They are selfed to get F2. Therefore, at each locus, the probability of getting a homozygous dominant F2 individual is 1/4. Therefore, probability of homozygous dominant at both loci is 1/16)

4. Continuing with the plants mentioned in question (2), a spiny purple plant is bred with a spiny white plant. Among the progeny, we find 29 spiny-purple, 32 spiny-white, 10 smooth-purple and 11 smooth-white. Deduce the genotypes of the parents.

*An examination of the individual loci indicates the following numbers- Spiny-61; smooth- 21 (this is close to 3:1 ratio).*

*Purple- 39; white- 43 (this is close to 1:1 ratio).*

*Therefore, it follows that with respect to smooth-spiny locus, both the parents were heterozygous while with respect to the purple-white locus, one was a heterozygote while the other was recessive homozygote.*

*(Ss Pp X Ss pp)*

5. Again, continuing with the plants mentioned in question (2), two spiny-purple plants are crossed and they produce a large number of seeds which are all collected and stored. Just two seeds are planted. One grows into a spiny-white plant and the other grows into a smooth-purple plant. If all the seeds were planted, what would be the expected phenotypes and their ratios?

*The two progeny indicate that the parents were heterozygous at both loci (otherwise, we cannot get the homozygous recessive characters- white and smooth). Therefore, this looks like a typical F2 cross. Therefore, we would expect to see the following ratio if all the seeds were planted-*

*(Purple spiny (9/16); purple smooth (3/16); white spiny (3/16); white smooth (1/16))*

6. Phenylketonuria is caused by a recessive autosomal allele. In the pedigree below, the female (dark circle) in the pedigree is affected with phenylketonuria. If person III-1 and III-2 were to marry (they are first cousins), what is the probability that their child will be affected? Assume that II-1 and II-5 are dominant homozygotes.

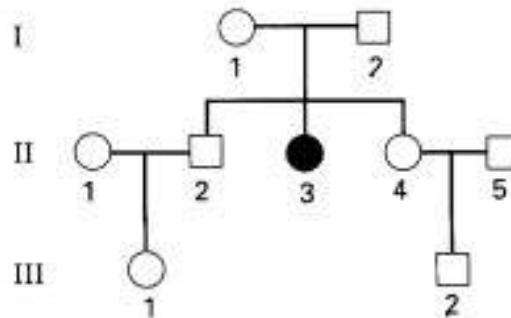

The pedigree indicates that the parents (I-1 and I-2) were heterozygotes. Therefore, the probability that II-2 and II-4 are heterozygotes is (2/3) each (and not 3/4 because we know that they are not affected by the disease).

The probability that a heterozygote parent passes the allele on to the progeny is (1/2).

Therefore, the for the progeny of III-1 and III-2 to be affected:-

II-2 should be heterozygous AND should pass on its affected allele to III-1 and III-1 should pass it on to its progeny. Therefore,

$$(2/3) \times (1/2) \times (1/2) = 2/12 = 1/6$$

Similar logic holds for transmission of the affected allele from II-4 to the progeny of III-2. Therefore,

$$(2/3) \times (1/2) \times (1/2) = 2/12 = 1/6$$

Therefore, total probability =  $(1/6) \times (1/6) = (1/36)$

7. Mendel used several characters for his crosses. Consider three of these- Purple flower dominant to white; Round seeds dominant to wrinkled; Yellow seed dominant to green. A pure breeding purple-wrinkled-yellow plant is crossed with a pure breeding white-round-green plant. (a) Write the genotypes of the parents **PPrrYY and ppRRyy**  
 (b) Write the genotype and phenotype of the F1 **PpRrYy Purple-Round-Yellow**  
 (c) How many different types of gametes can the F1 produce? **8**  
 (d) What proportion of the F2 progeny will be heterozygous at all loci?  
 $(1/2) \times (1/2) \times (1/2) = (1/8)$   
 (e) What proportion of the F2 progeny will be Purple-Round-Green?  
 $(3/4) \times (3/4) \times (1/4) = (9/64)$   
 (f) What assumption(s) did you make in answering these questions?  
**Independent assortment.**

**For the next questions, you should use the Chi-Square tables given below. You CANNOT use ANY OTHER Chi-square table. Answer the following questions-**

8. Fill in the blanks in the table below

Degrees of Freedom (df)	Alpha ( $\alpha$ )	Chi-Square (critical) Value
1	0.05	3.841
5	0.025	12.833
14	0.1	21.064
19	0.975	8.907

9. In the garden pea, yellow cotyledon color is dominant to green, and inflated pod shape is dominant to the constricted form. In a cross of pure breeding Yellow-Inflated to a pure breeding green-constricted, the F2 progeny were as follows-

193 green, inflated  
 184 yellow constricted  
 556 yellow, inflated  
 61 green, constricted

Do these two genes assort independently? Support your answer using Chi-square test for goodness of fit. Show all the steps for doing a Chi-square test ie., state the null hypothesis, Alpha, df, Critical Chi-square value, calculated chi-square value and the final conclusion.

H0: There is no difference between the expected and observed distributions

Alpha = 0.05

df = 3

Critical Chi Squared value = 7.815

Trait	O	E	(O-E) <sup>2</sup> /E
green, inflated	193	186.375	0.2355
yellow constricted	184	186.375	0.0303
yellow, inflated	556	559.125	0.0175
green, constricted	61	62.125	0.0204
Total	994	994	0.3036

Calculated Chi Squared value = 0.3036

Since calculated Chi squared value is lower than the critical chi squared value, we DO NOT REJECT the null hypothesis.

- Three scientists, Erich von Tschermak-Seysenegg, Carl Correns and Hugo De Vries rediscovered the work of Mendel in late 1890s. Two of them, Tschermak and Correns, repeated some of the classic crosses of Mendel. Both of them crossed plants having yellow pods with plants having green pods. The F1 were all yellow. The F1 were selfed to yield F2. Tschermak, in his experiments, observed 3580 yellow and 1190 green progeny in the F2. Correns found 1394 yellow and 453 green F2 progeny in his experiments. Use the Chi-squared test for goodness of fit to test if the results (ie., phenotypic distribution in F2) obtained by these two scientists are in agreement with the expectations based on Mendel's experiment.

H0: There is no difference between the expected and observed distributions

Alpha = 0.05

df = 1

Critical Chi Squared value = 3.841

	Tschermak			Correns		
Trait	O	E	(O-E) <sup>2</sup> /E	O	E	(O-E) <sup>2</sup> /E
Yellow	3580	3577.5	0.001747	1394	1385.25	0.0552698
Green	1190	1192.5	0.005241	453	461.75	0.1658094
Total	4770	4770	0.006988	1847	1847	0.2210792

Calculated Chi Squared value = 0.006988 (Tschermak) and 0.2210 (Correns)

Since calculated Chi squared value is lower than the critical chi squared value, we DO NOT REJECT the null hypothesis.