

Regulation of Eukaryotic Transcription

Outline:

- Overview
- Structural classification of eukaryotic transcription factors
- Transcription control mechanisms
 - by altered states of chromatin
 - through Mediator
 - by epigenetic mechanisms
- Control of transcription factor activity
- Nuclear receptors

Transcription control elements in eukaryotes

(a) Mammalian gene

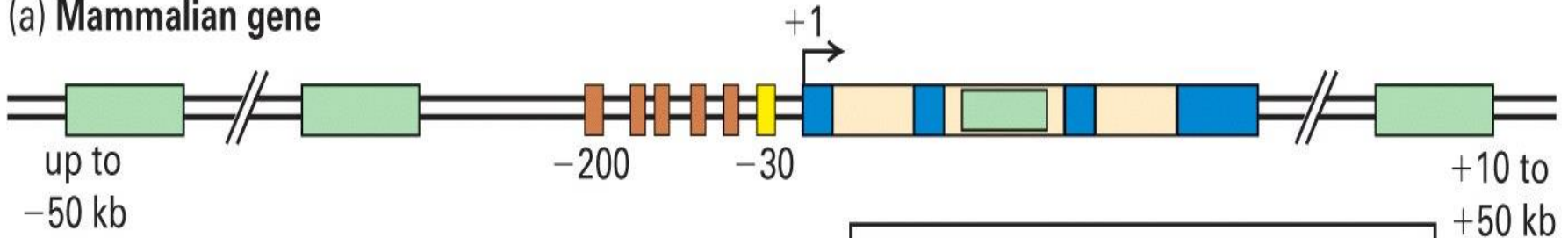

(b) *S. cerevisiae* gene

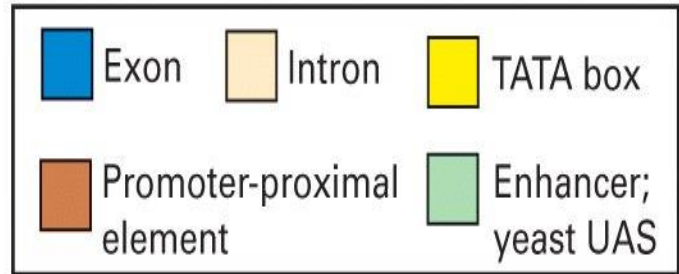
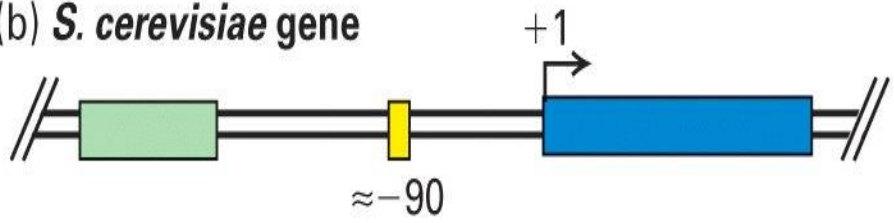

A schematic picture of transcriptional initiation in eukaryotes

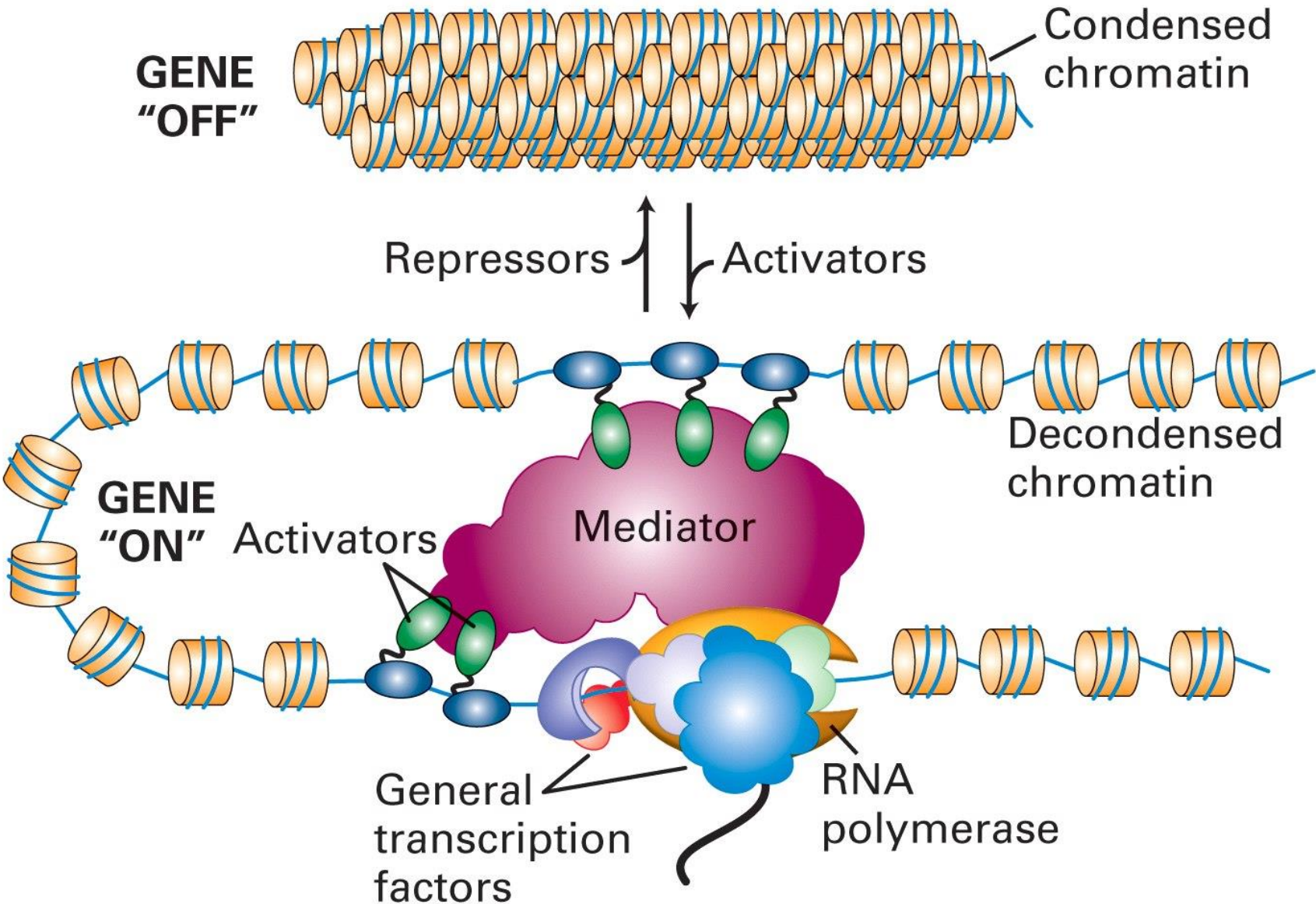

Structural classification of specific eukaryotic transcription factor domains

Homeodomains

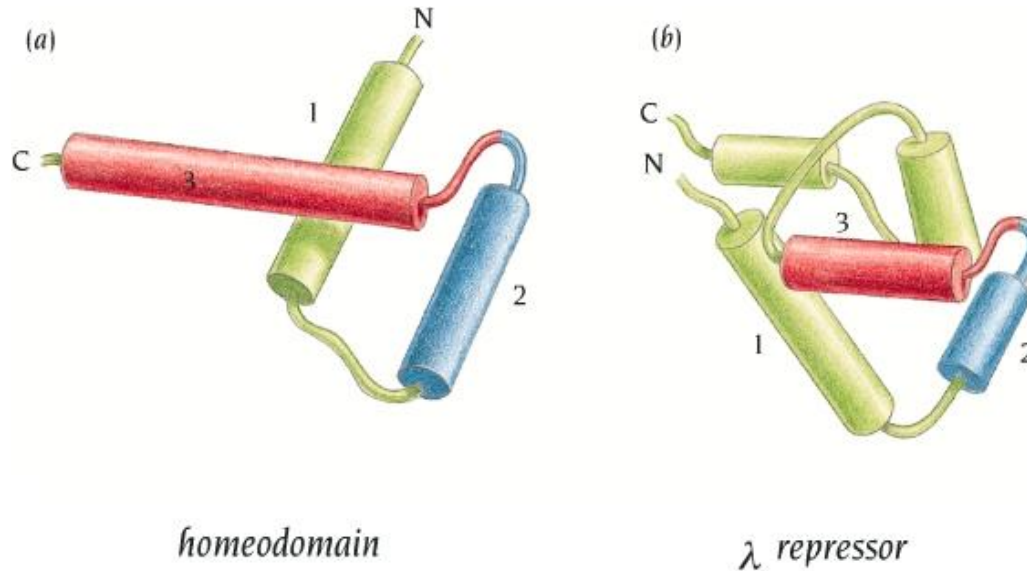

- Sequences of 60 residues that function as DNA binding domains of transcription factors
- Built up from 3 helices, where helices 2 and 3 form helix-turn-helix motif similar to those in prokaryotic DNA binding proteins
- First identified in *Drosophila*, where mutant homeodomains cause so-called homeotic transformations. Those are bizarre developmental anomalies – like legs growing from head in place of antennae.

Homeotic transformations



Flies with 4 wings (left) or legs on the head (right)-- Homeotic transformations that alter the identities of body segments

Binding of the helix-turn-helix motif of an *Antennapedia* homeodomain protein in the major groove of the homeobox

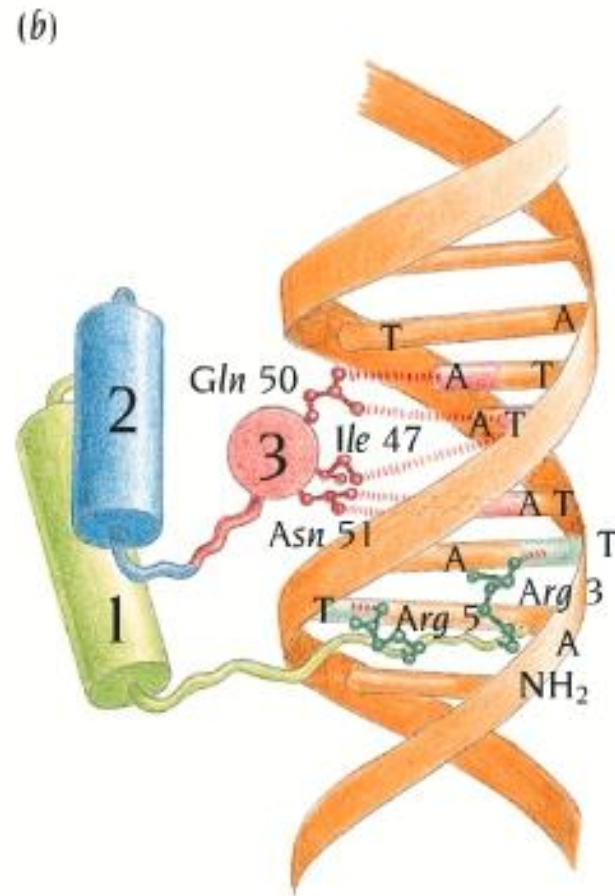
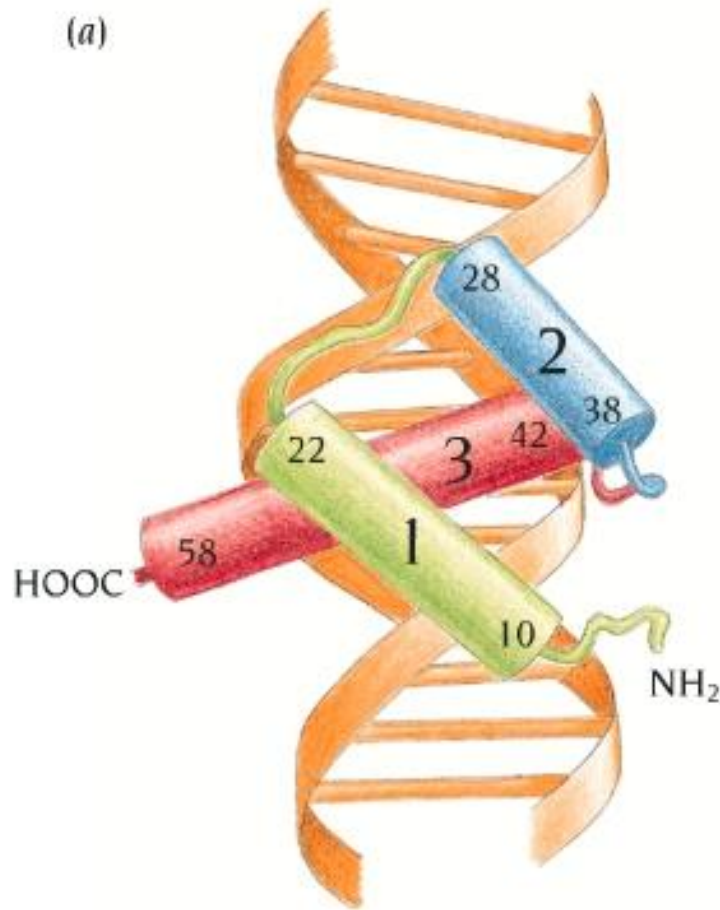

Homeodomains can operate in tandems with similar or different DNA binding domains

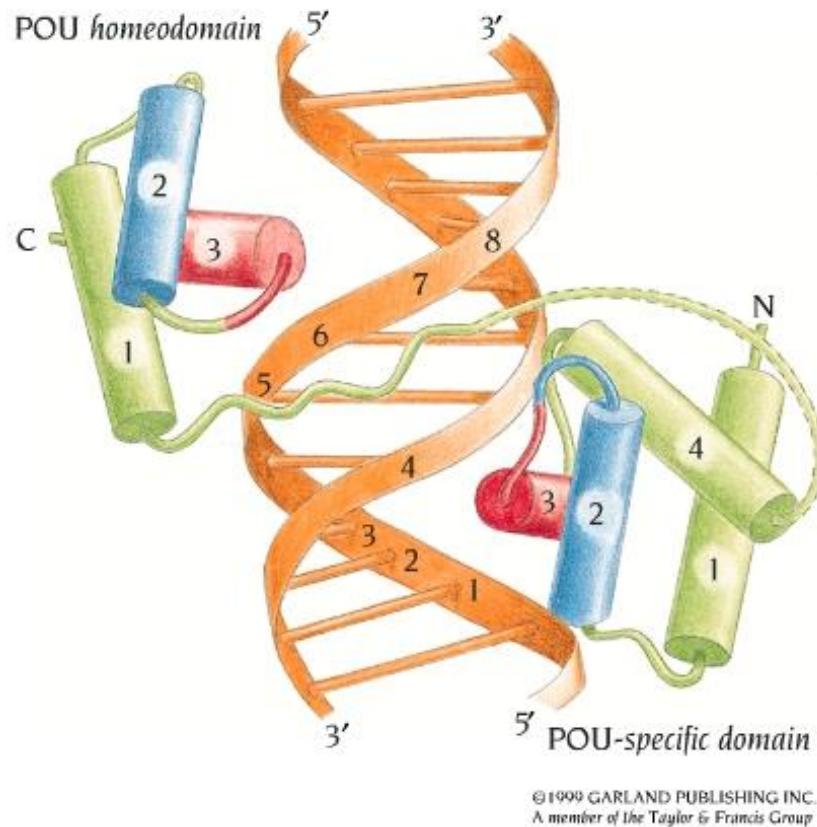

- DNA binding of the two domains in the POU region of the human protein Oct-1, which regulates transcription of small nuclear RNA genes and the histone H2B gene

Zinc fingers

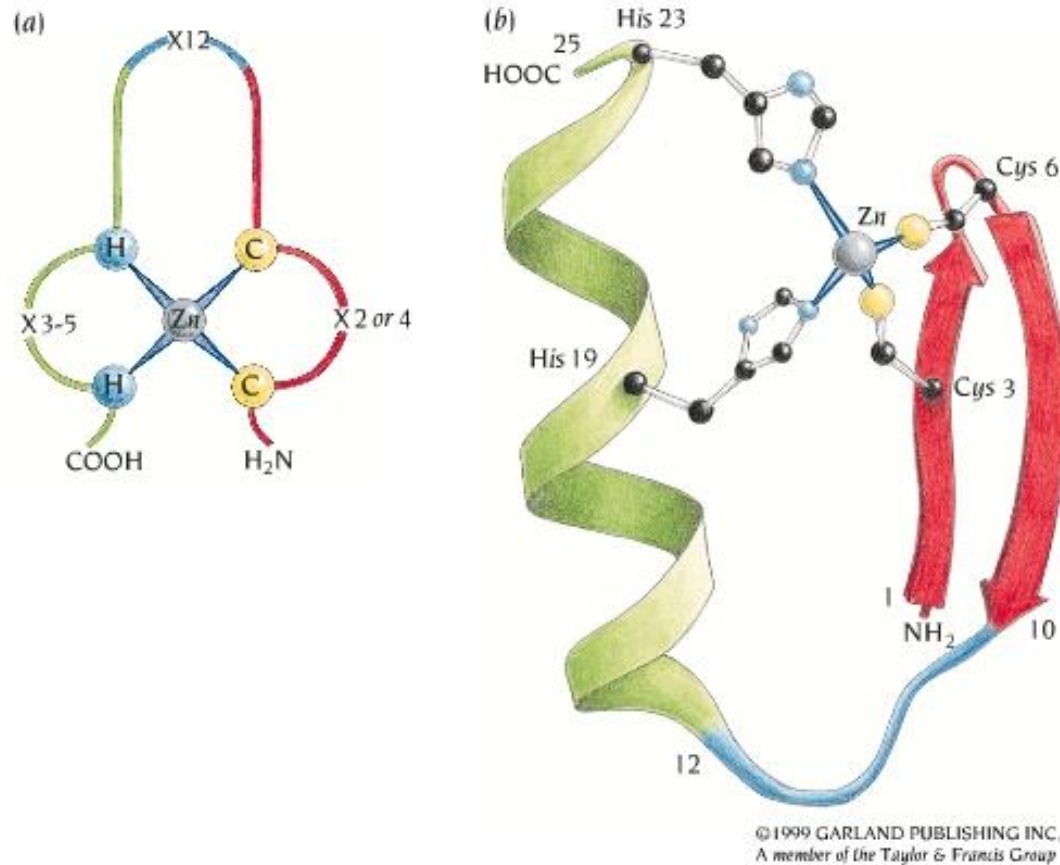

- The classic zinc finger motif with two histidines and two cysteines binding to the zinc ion (C₂H₂ type)
- Other mononuclear zinc finger motifs can have three or four cysteines. The 3D structures of those are quite different from C₂H₂ type.

- Zinc finger proteins are multi-domain, with 1-60 tandem zinc finger DNA-binding domains and several other domains which may be responsible for dimerization, ligand or other protein binding

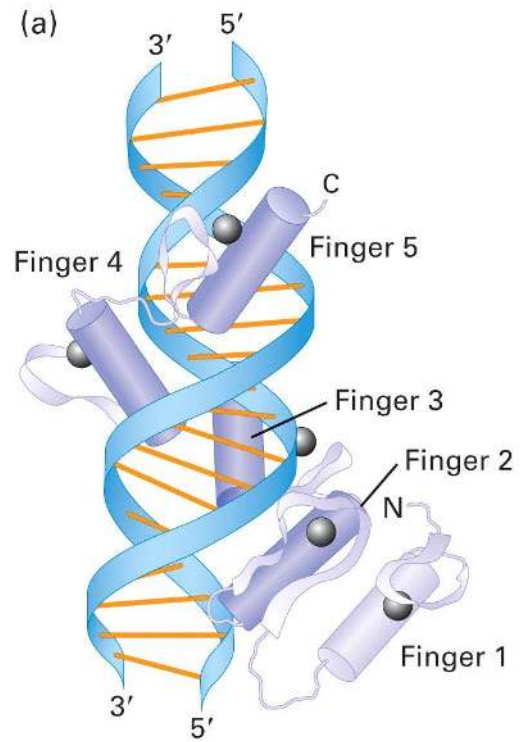
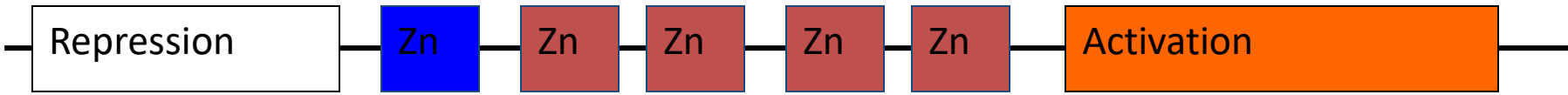

Example: Human GLI1 protein has 5 ZNF domains and additional domains for both transcription activation and repression. Only 4 of 5 ZNFs bind to DNA

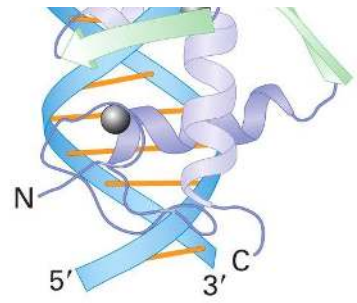

A binuclear zinc finger binding in GAL4

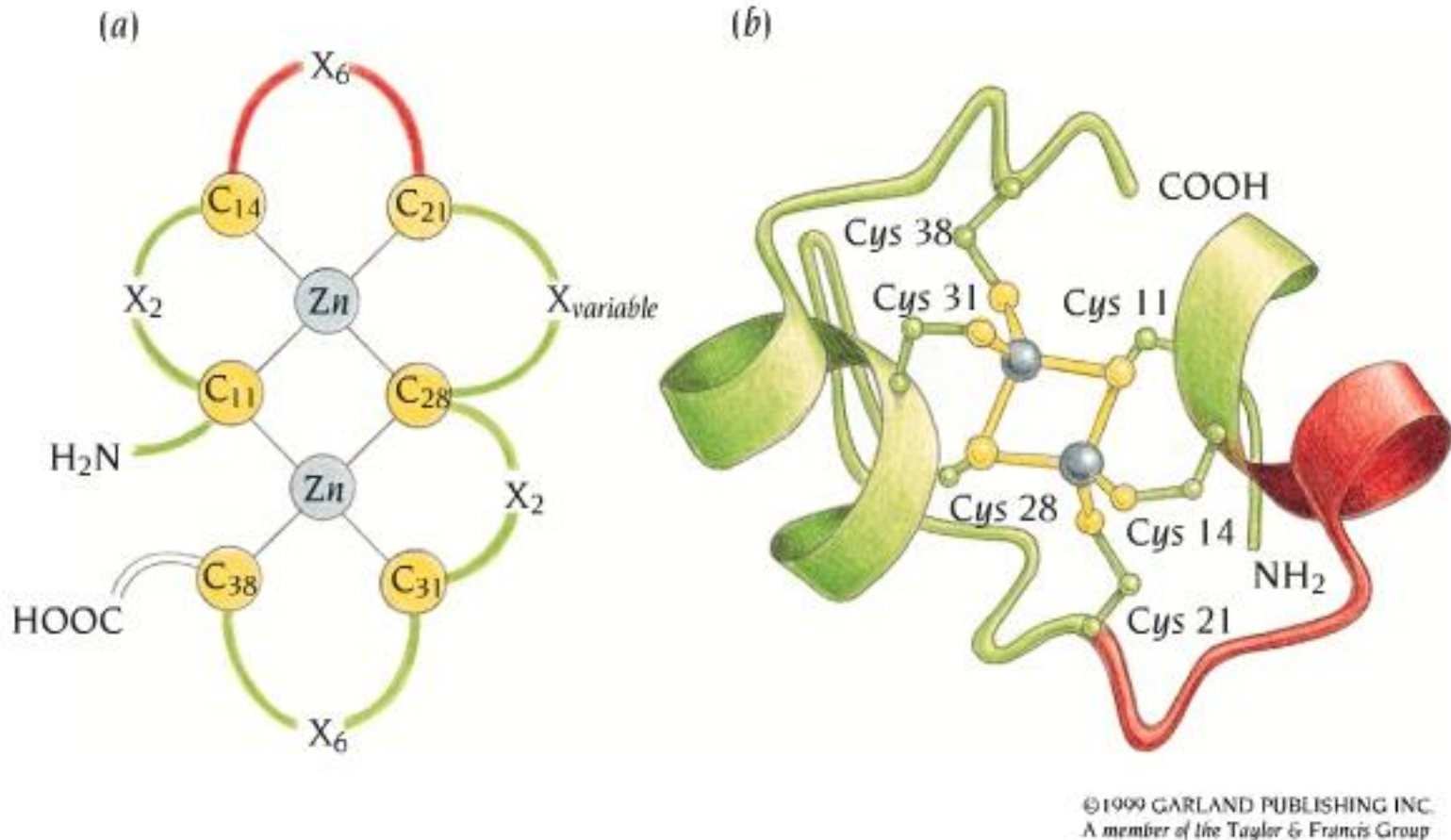

- Binuclear zinc finger proteins contain six Cys/His residues and two zinc ions

Leucine zippers

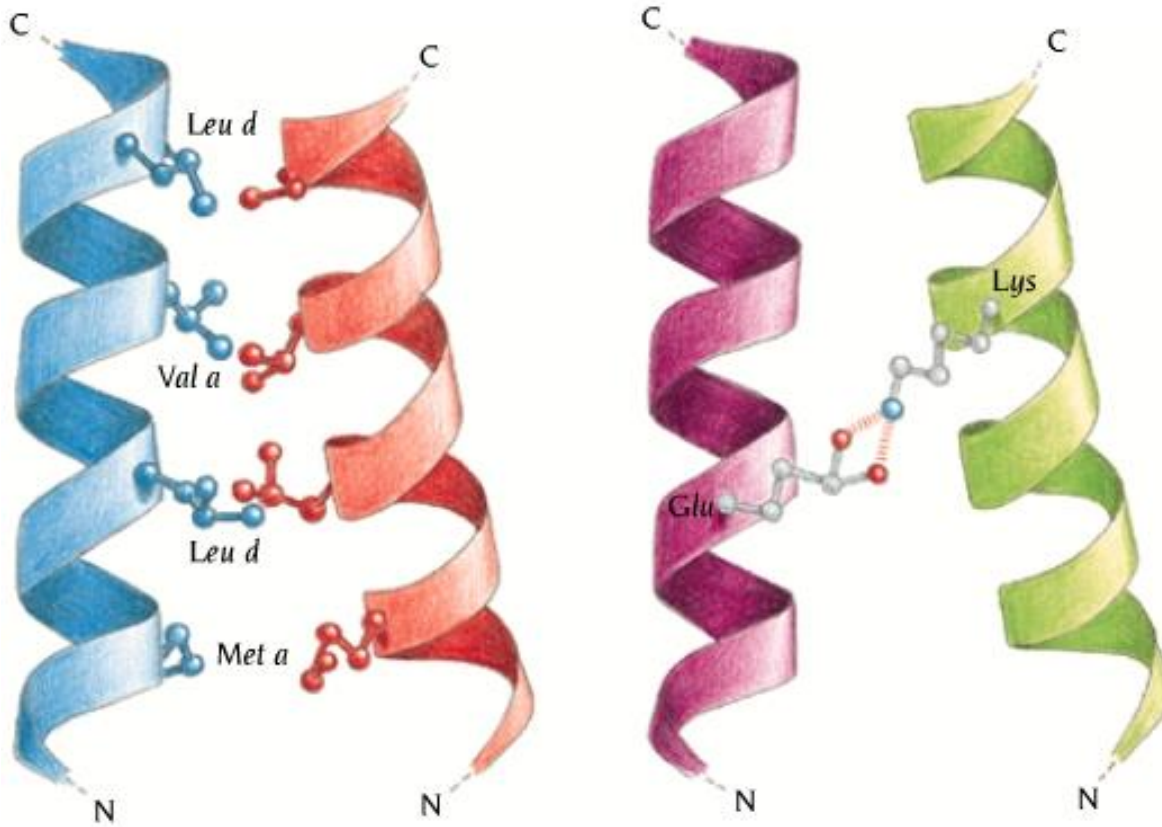

© 1999 GARLAND PUBLISHING INC.
A member of the Taylor & Francis Group

- Leucine zipper motif is built of two α -helices, which are kept together by hydrophobic interactions. Each seventh residue is leucine, hence the name leucine zipper
- Dimer formation can be promoted by additional charge interactions

Binding of leucine zippers to DNA

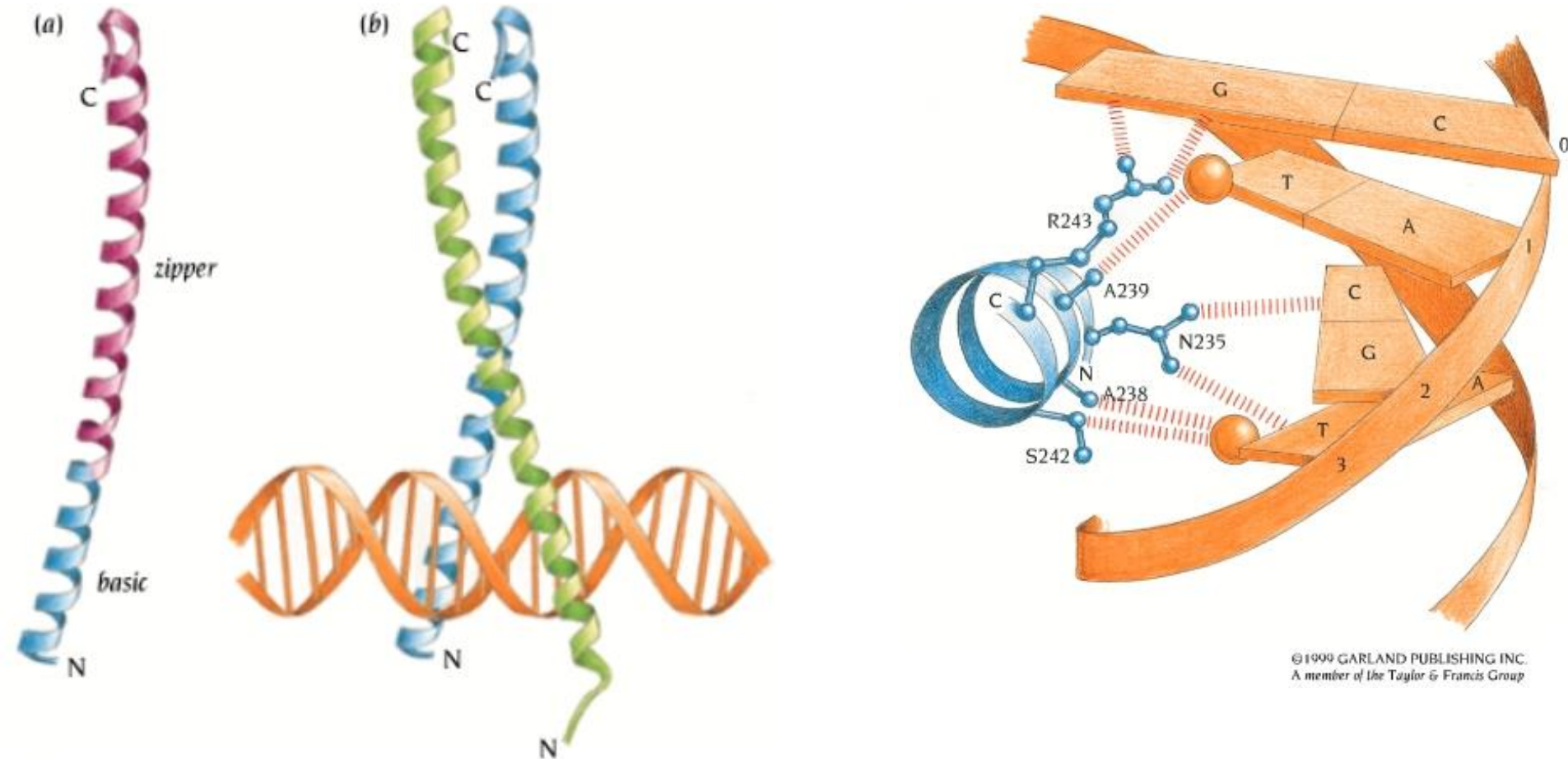

- Leucine zipper DNA binding proteins are **homo or heterodimers**
- The C-terminal part of helice contains leucine zipper dimerization region, whereas N-terminal part binds to DNA and contains many basic residues

Helix-loop-helix domains

- Helix-loop helix domains are somewhat similar to leucine zippers, except that a four-bundle helix motifs hold together basic DNA-binding helices



©1999 GARLAND PUBLISHING INC.
A member of the Taylor & Francis Group

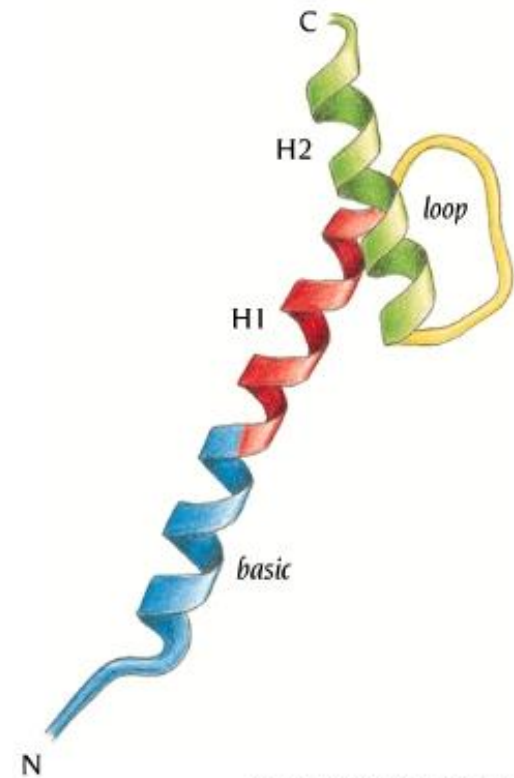

©1999 GARLAND PUBLISHING INC.
A member of the Taylor & Francis Group

Structure of human oncogene Max is an example of combined leucine zipper – helix-loop-helix protein

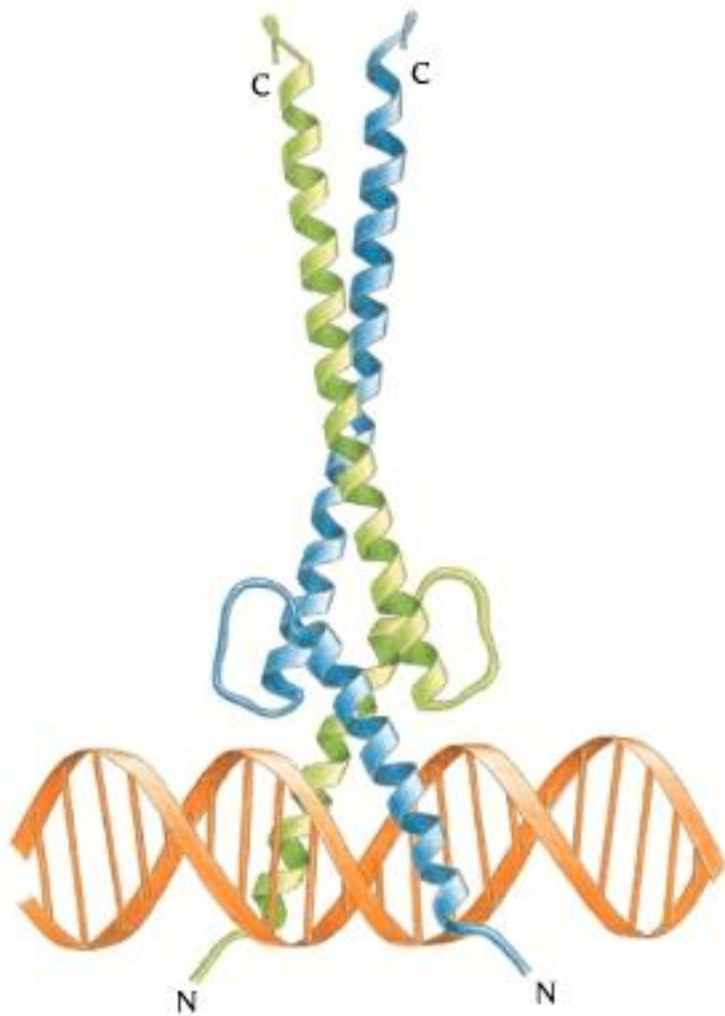

©1999 GARLAND PUBLISHING INC.
A member of the Taylor & Francis Group

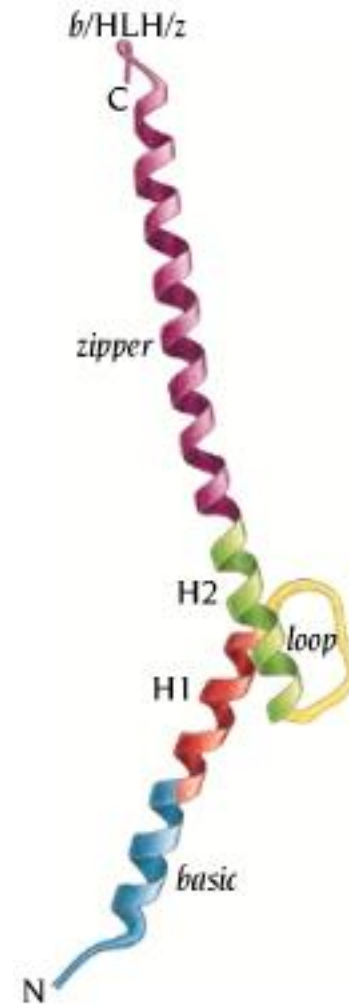

©1999 GARLAND PUBLISHING INC.
A member of the Taylor & Francis Group

Other eukaryotic DNA-binding domains

Rel homology domains (NFkB, NFAT)

Stat protein family

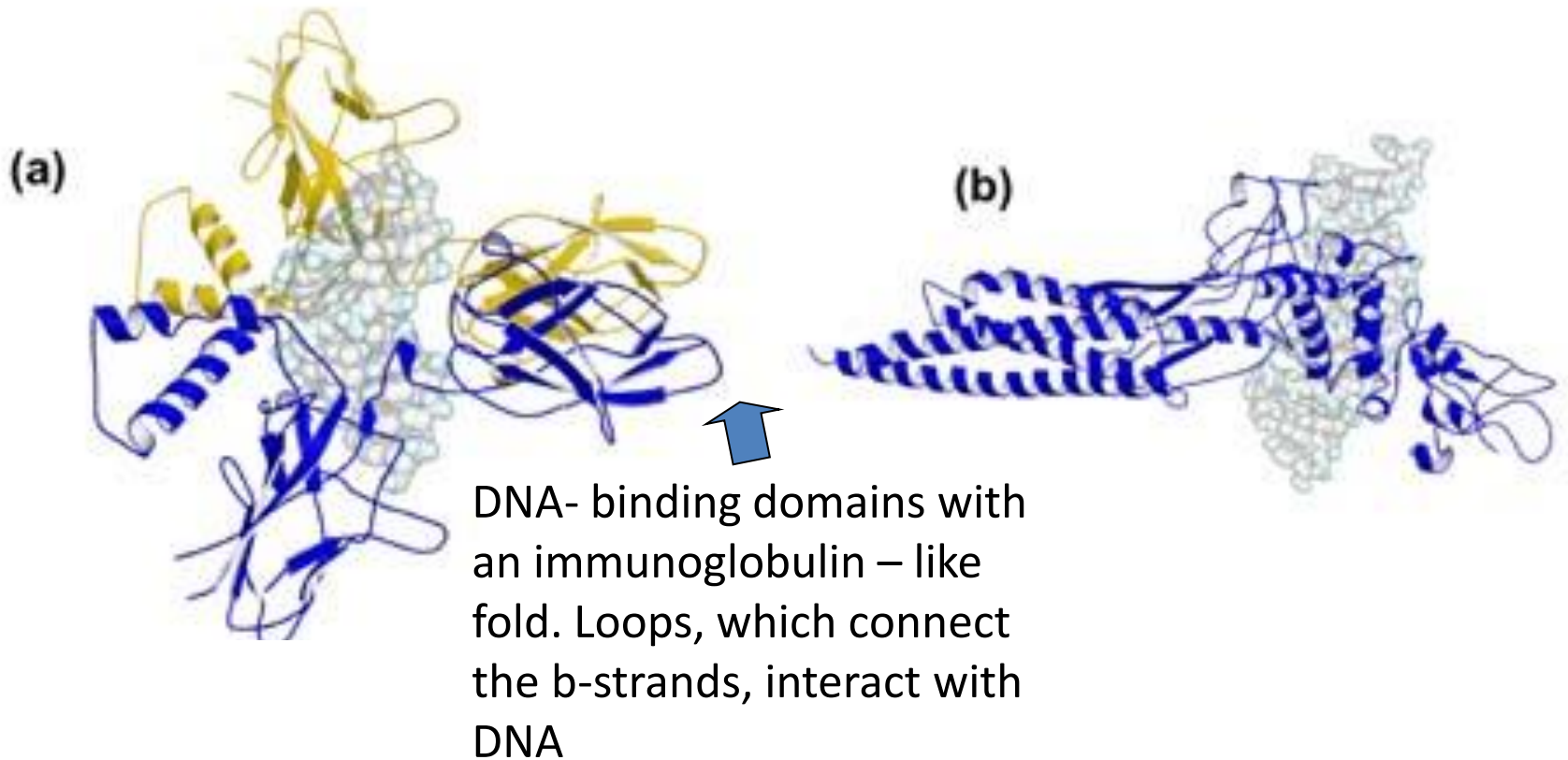

Homo- and heterodimeric combinations of transcription factors

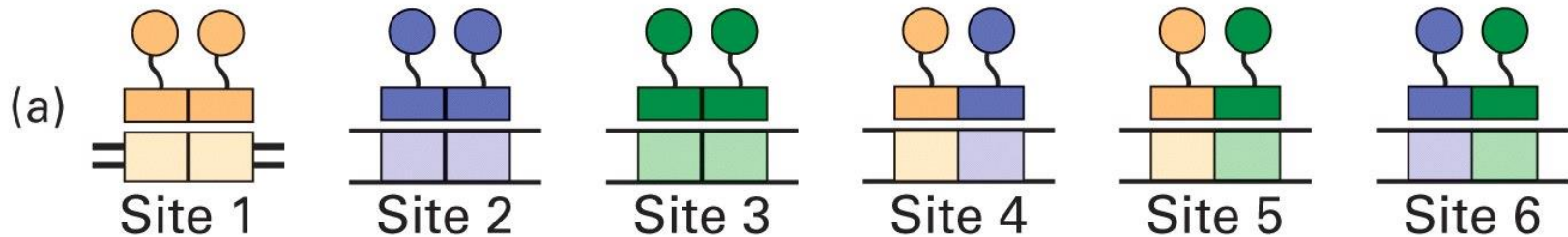
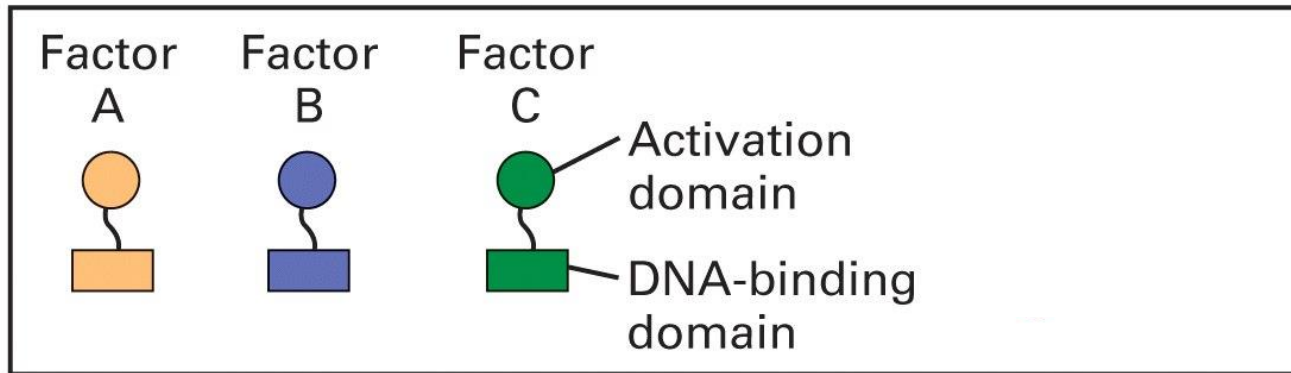

- From three different DNA-binding protein monomers it is possible to create six different dimers with distinct binding sites

Cooperative binding of NFAT and AP1 transcription factors at IL-2 promoter

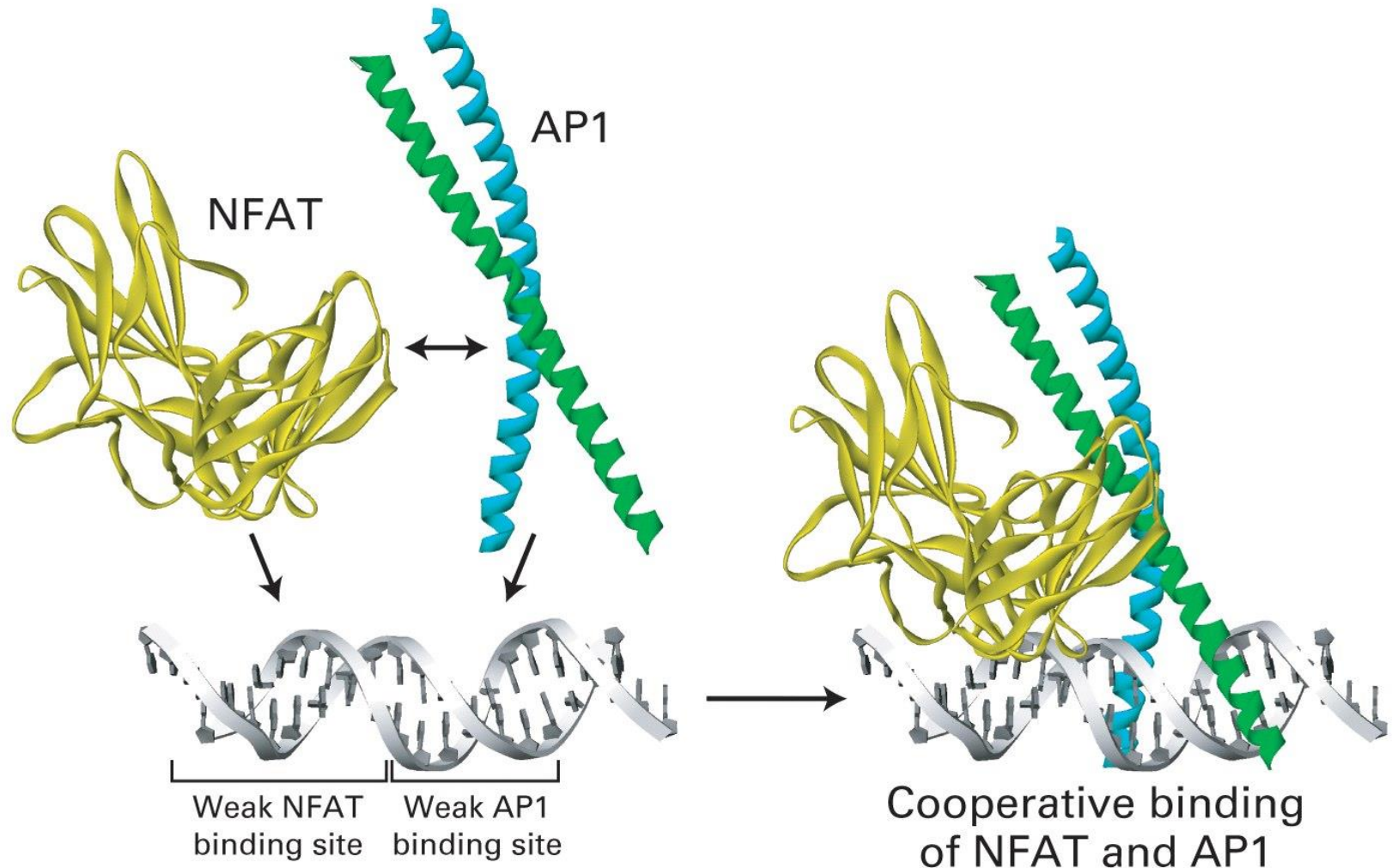

Cooperative binding of specific transcription factors can form an enhanceosome

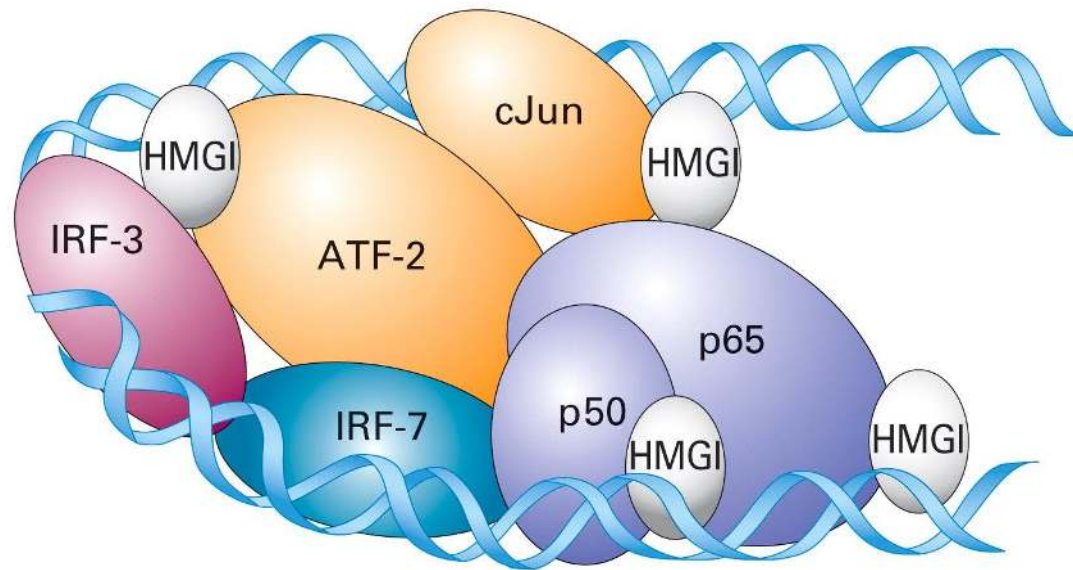

Scheme for enhanceosome formation at b-interferon enhancer. Two monomeric factors IRF3 and IRF7 and two dimeric ATF-2/cJun and p50/p65 (NF- κ B). HMGI is sequence-nonspecific factor, which bends DNA by binding in minor groove. It also coordinates the binding of other proteins each to other.

Molecular mechanisms of transcription activation and repression

- 1. Chromatin mediated transcription control
- 2. Transcription control through the Mediator
- 3. Epigenetic control through DNA methylation

Background: nucleosome structure

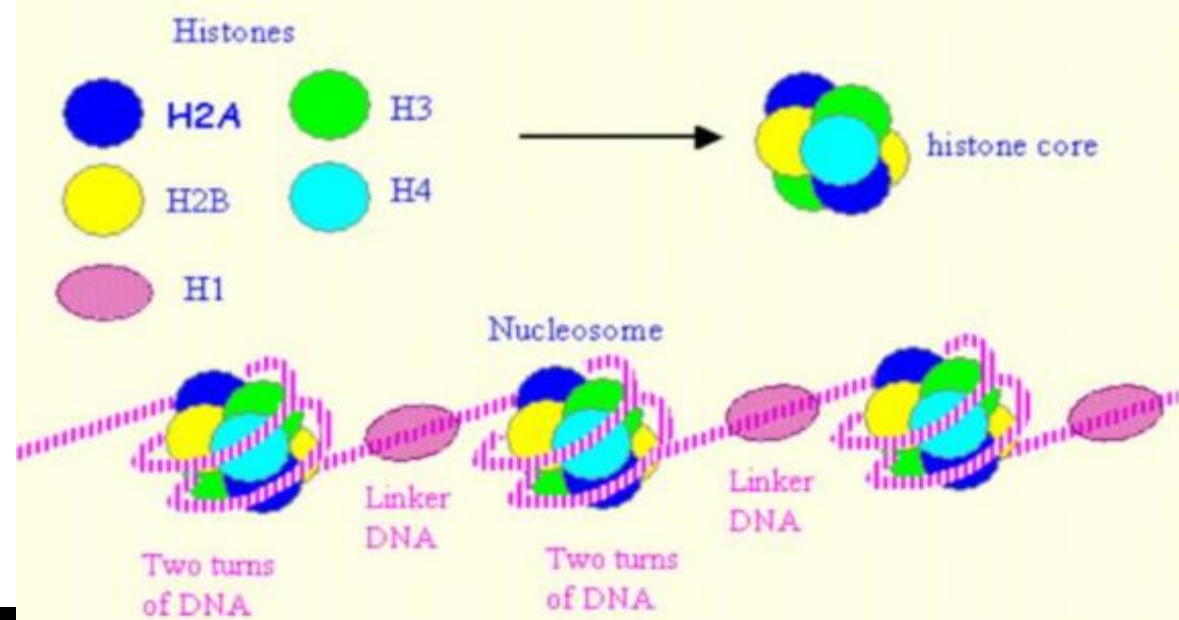

nucleosome core particle

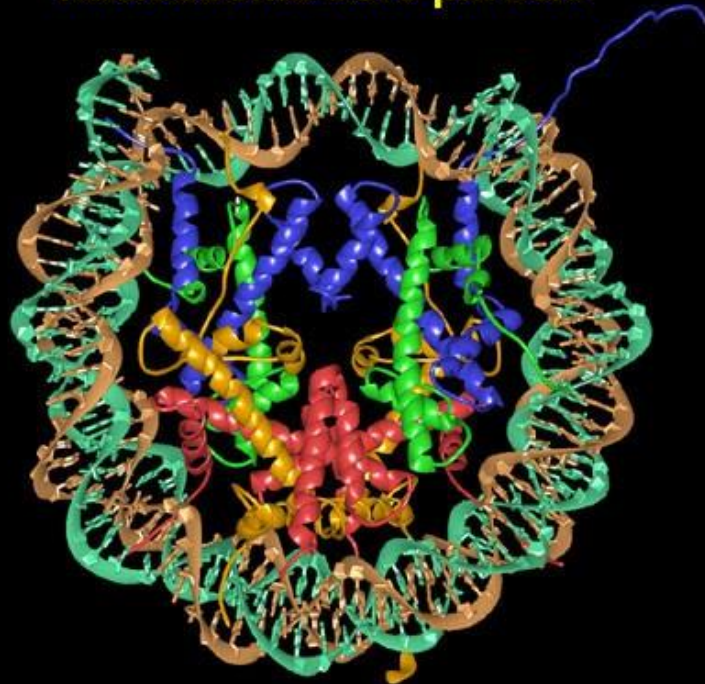

- H2A
- H2B
- H3
- H4

Tim Richmond, 1997

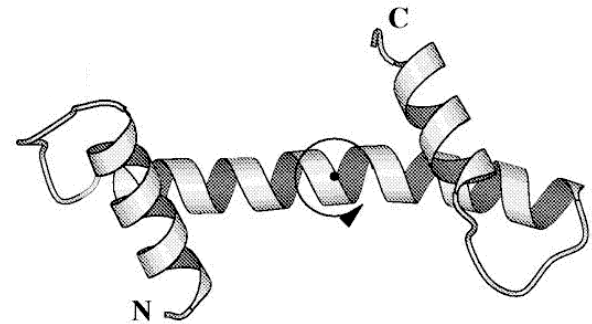

Histone monomer

Background: chromatin structure

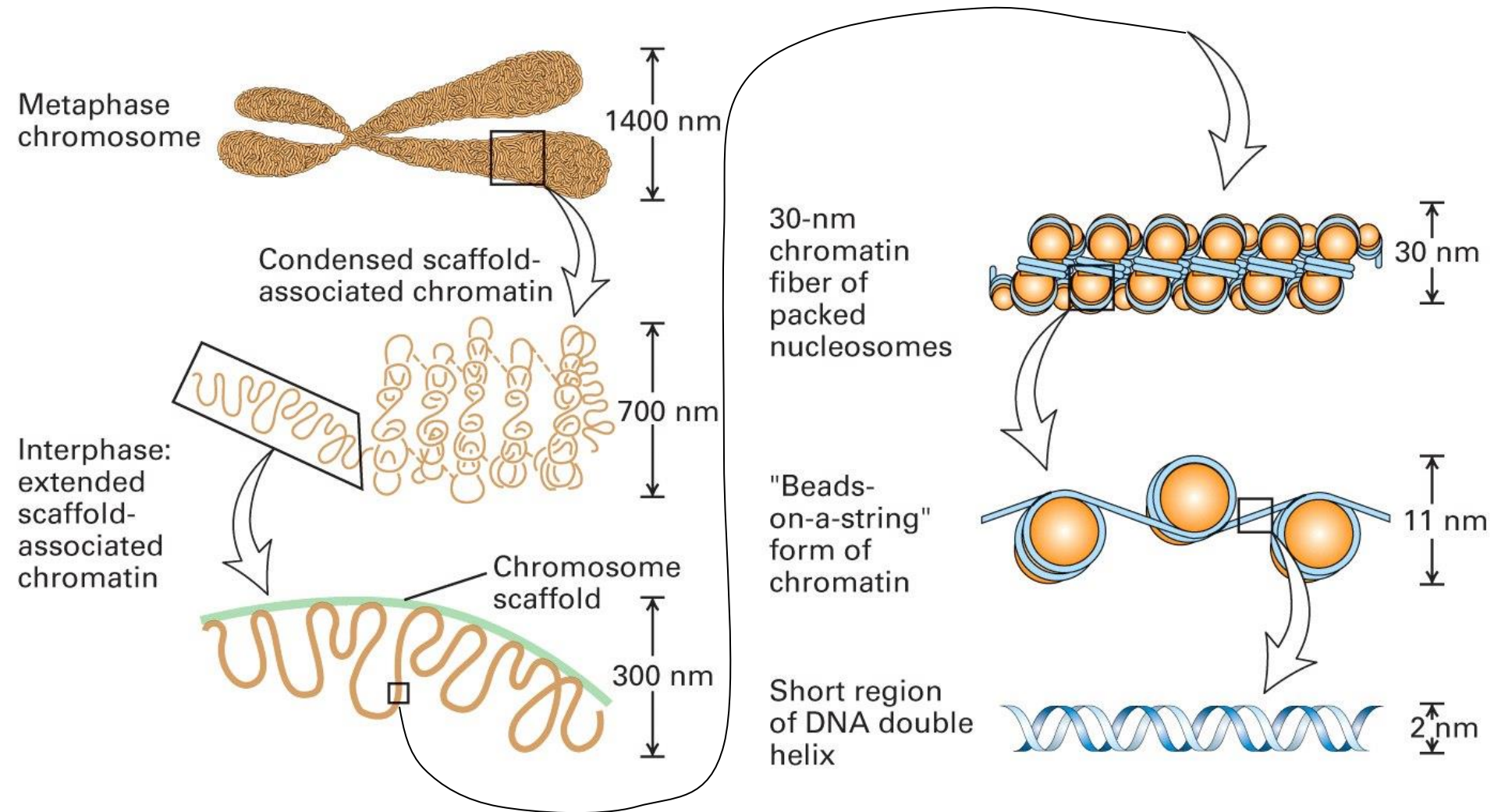

Acetylation of the N-terminal sequence of histone H3

- ART**K**QTAR**K**STGG**K**APRKQL

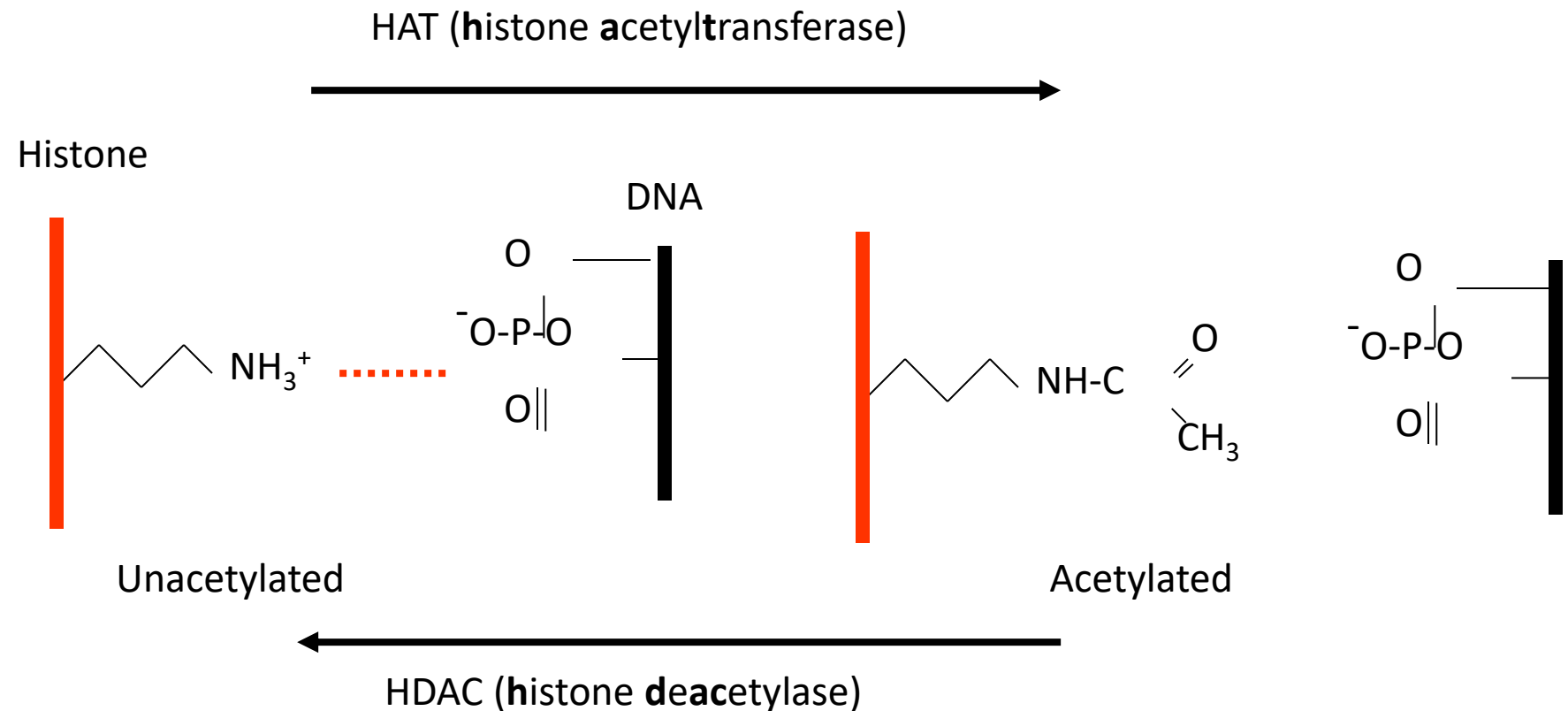

(a) Repressor-directed histone deacetylation

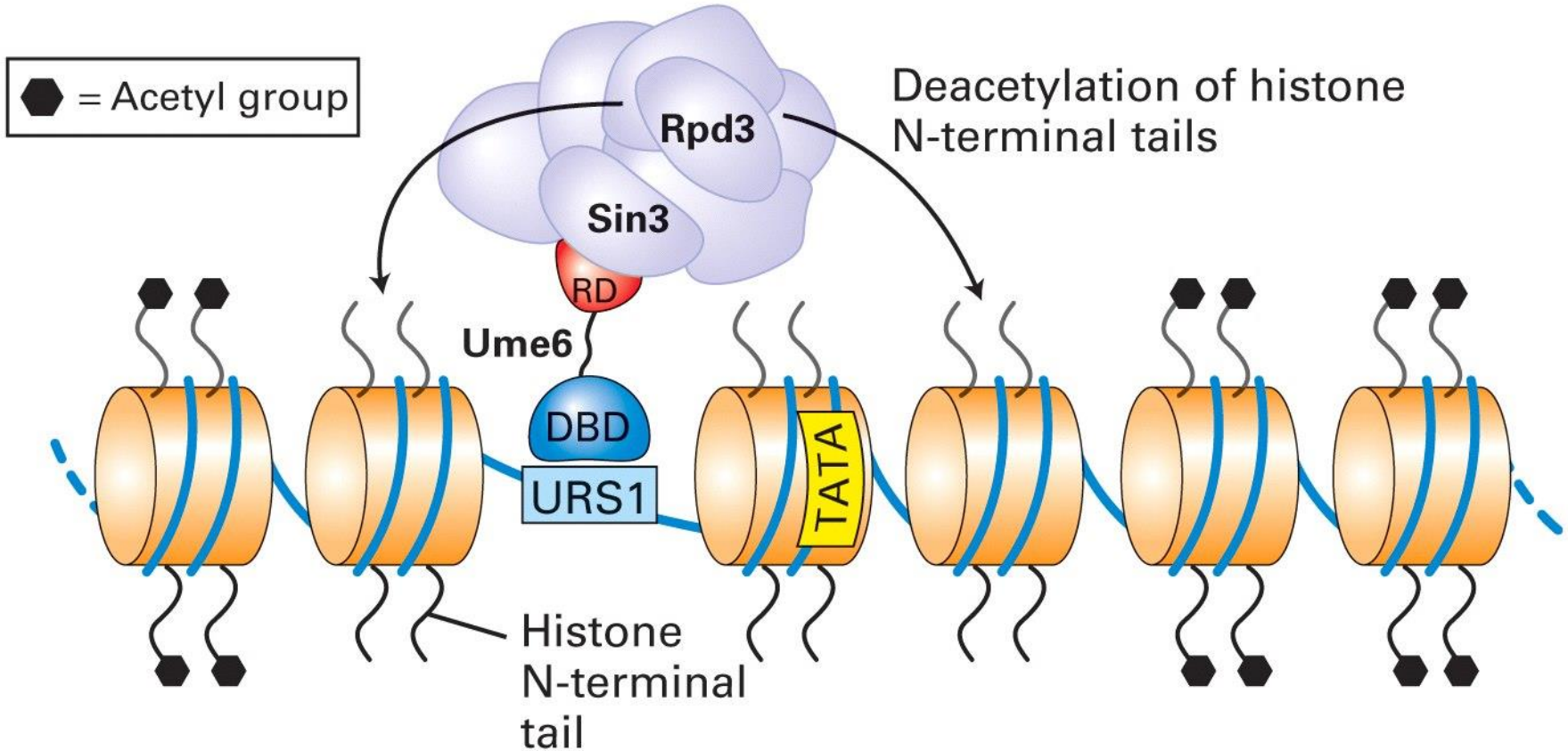

URS1 – Upstream regulatory sequence

DBD and RD – DNA binding and repressor domains of UME6 repressor

RPD3 – yeast histone deacetylase (component of deacetylation complex)

Sin3 – RD binding component of deacetylation complex

(b) Activator-directed histone hyperacetylation

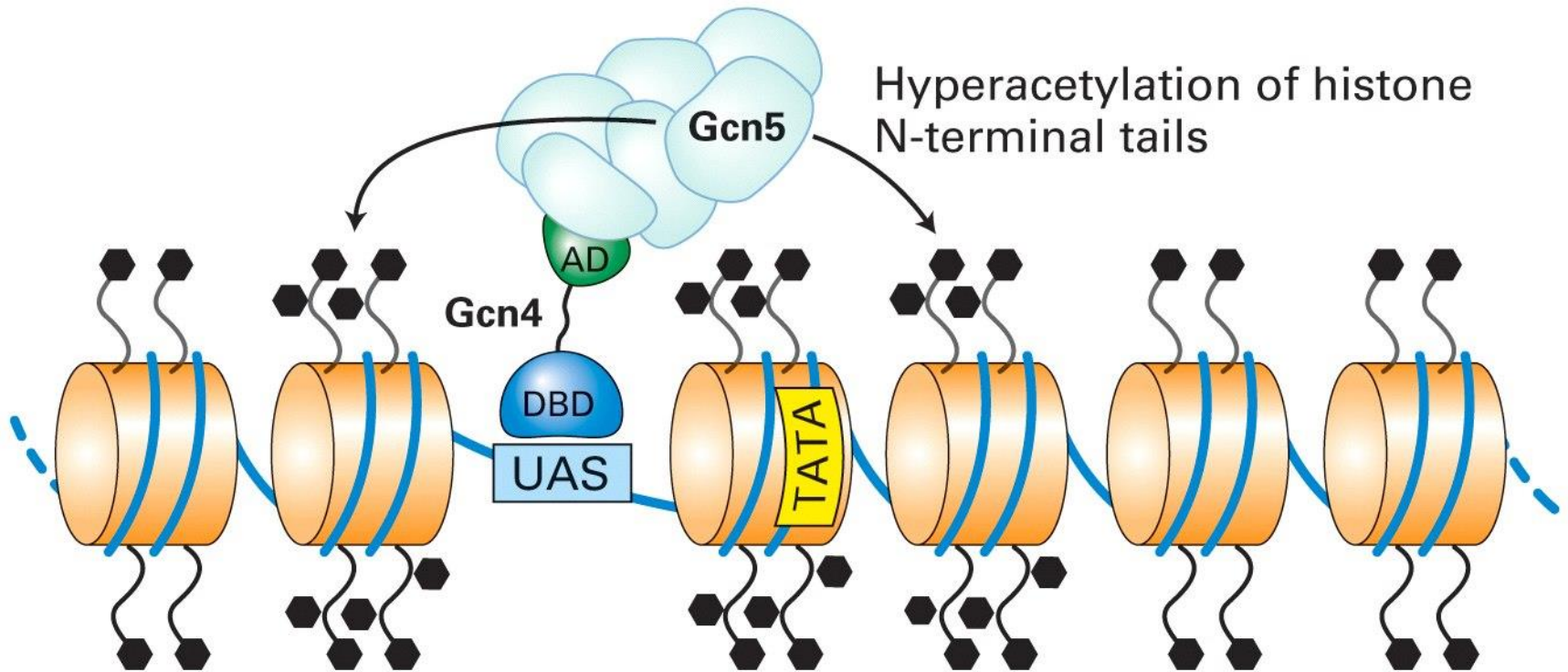

UAS – upstream activation sequence

AD – activation domain of Dcn4 transcription activator

Gcn5 – histone acetylase subunit of acetylation complex

Chromatin remodelling factors

- Chromatin remodelling factors are multiprotein complexes with some subunits showing helicase activity
- Chromatin remodelling complex SWI/SNF transiently dissociates DNA from the surface of nucleosomes, decondensing the chromatin and making the DNA more accessible to transcription factors
- The activity of complex may result also in transcription repression, probably by exposing the histone tails to deacetylases or by assisting in folding of chromatin into higher-order structures

SWI5 binds to enhancer and recruits SWI/SNF

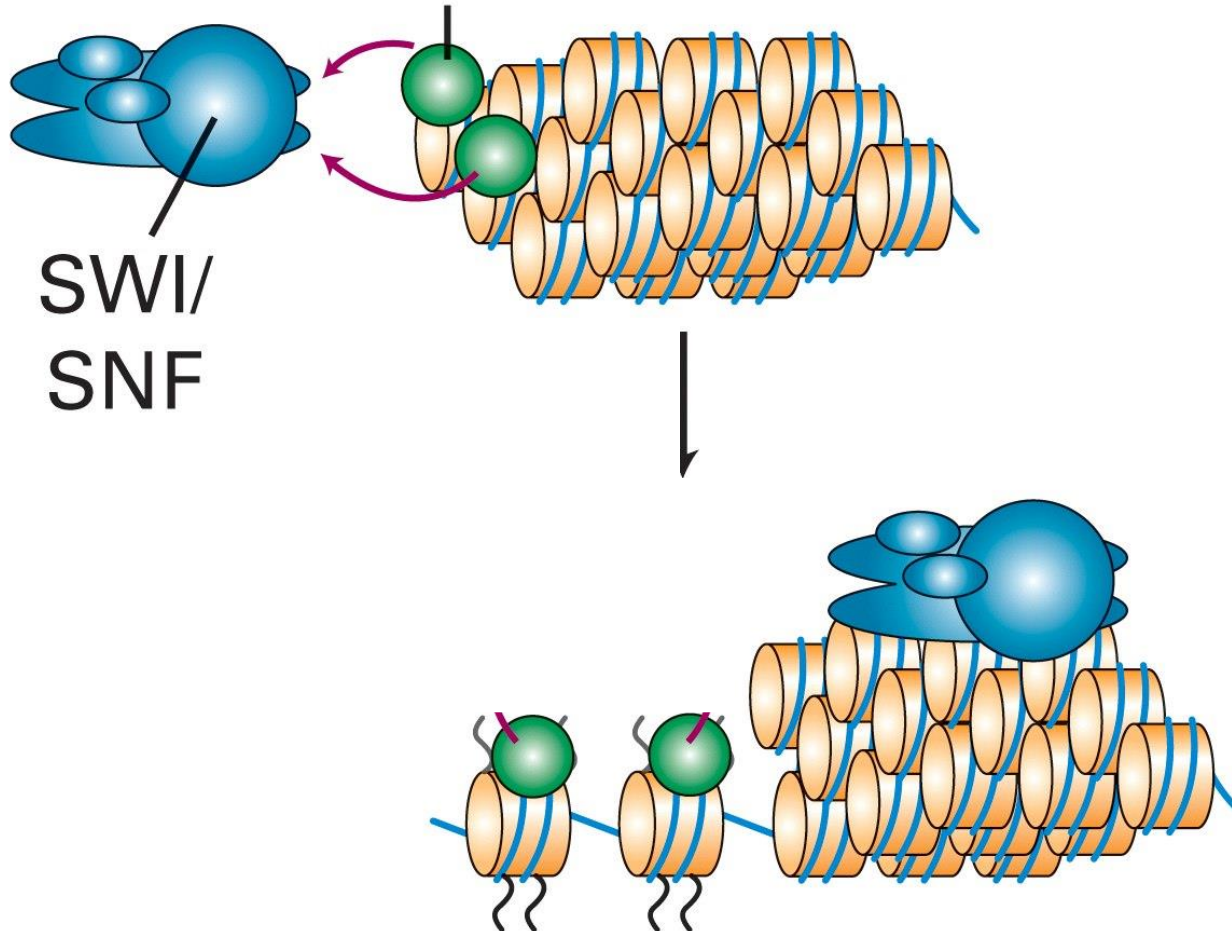

Transcription regulation through Mediator

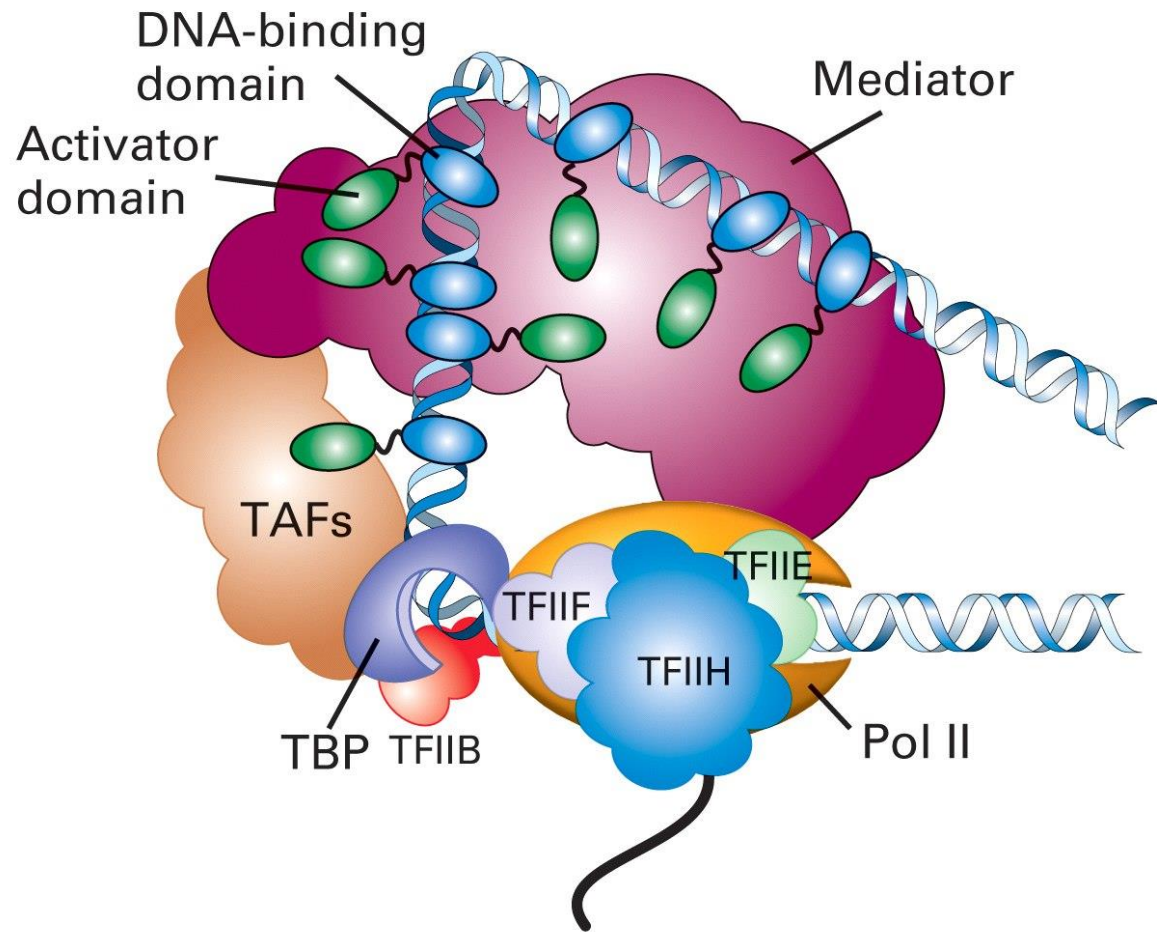

Structure of yeast and human mediator complexes

(a) Yeast mediator–Pol II complex

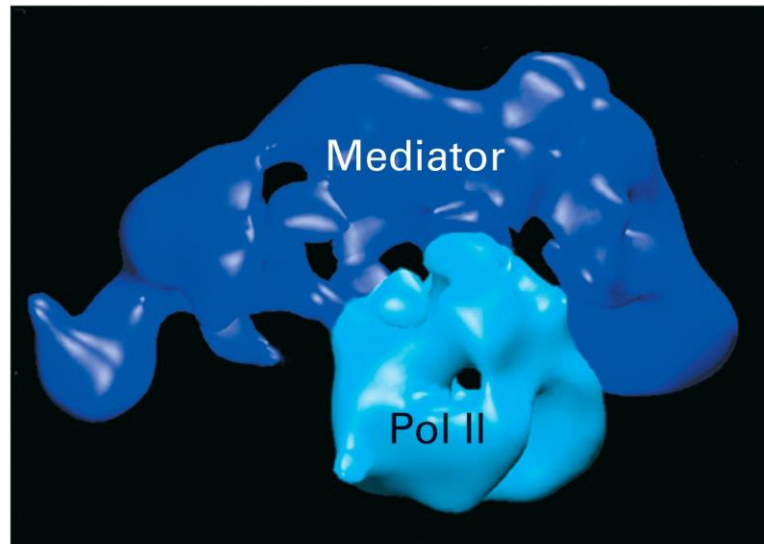

(b) Human mediator

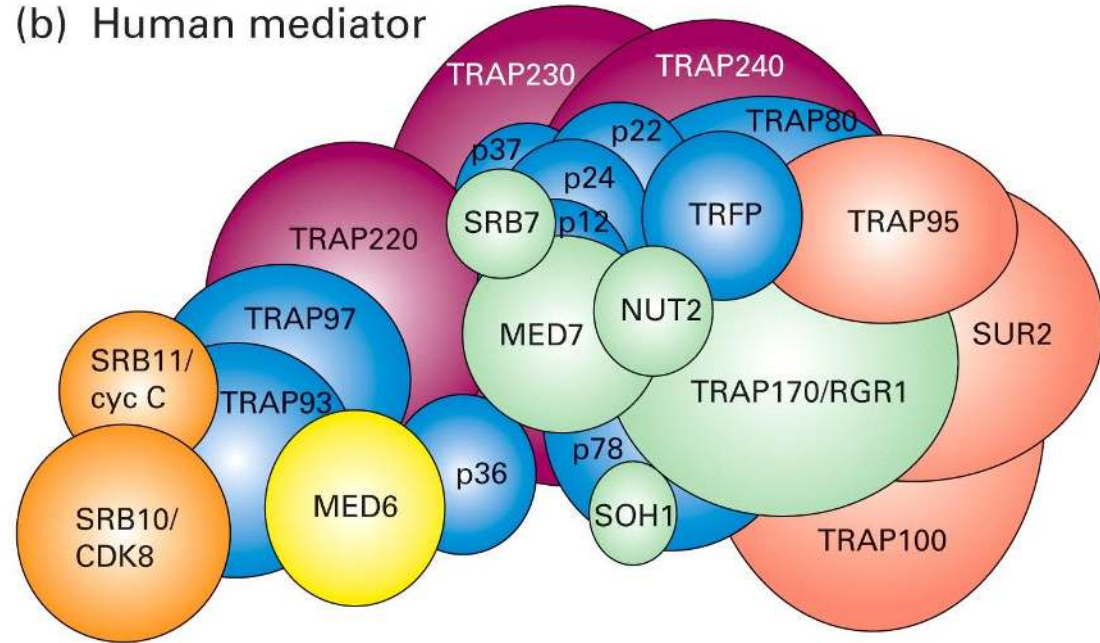

- Composed of ~20 subunits which are arranged in modules
- Some subunits interact with RNA Pol II, others – with activators
- One subunit has histone acetylase activity which might keep the promoter region in hyperacetylated state
- Some subunits are required for expression of all genes (“core subunits”) whereas others are required for specific subsets of genes

There is a long way from condensed chromatin to mRNA expression...

Gene packed in condensed chromatin

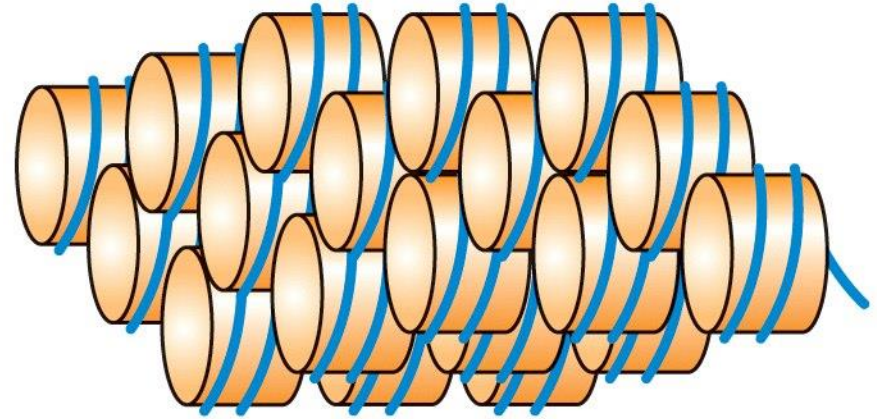

1



SWI5

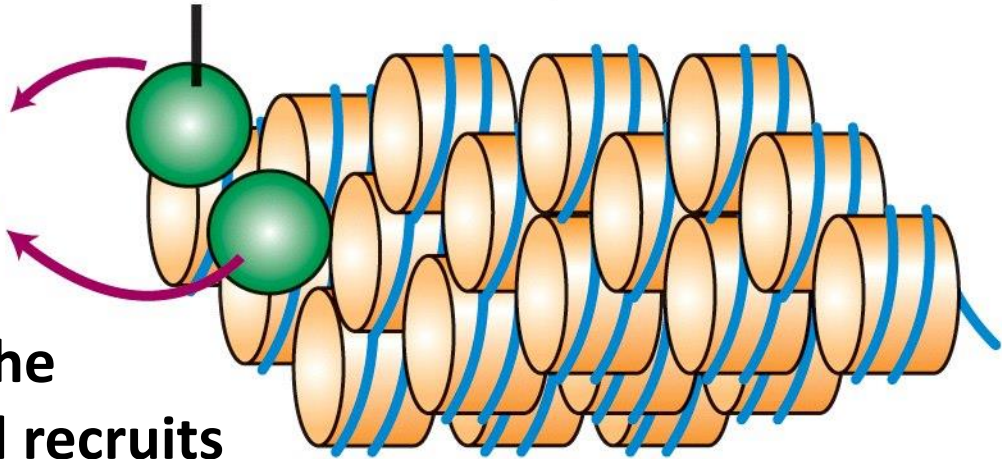
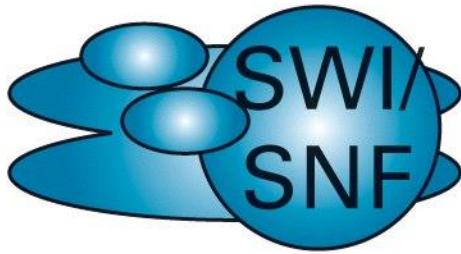

SWI5 protein binds to the enhancer sequence and recruits chromatin remodelling complex

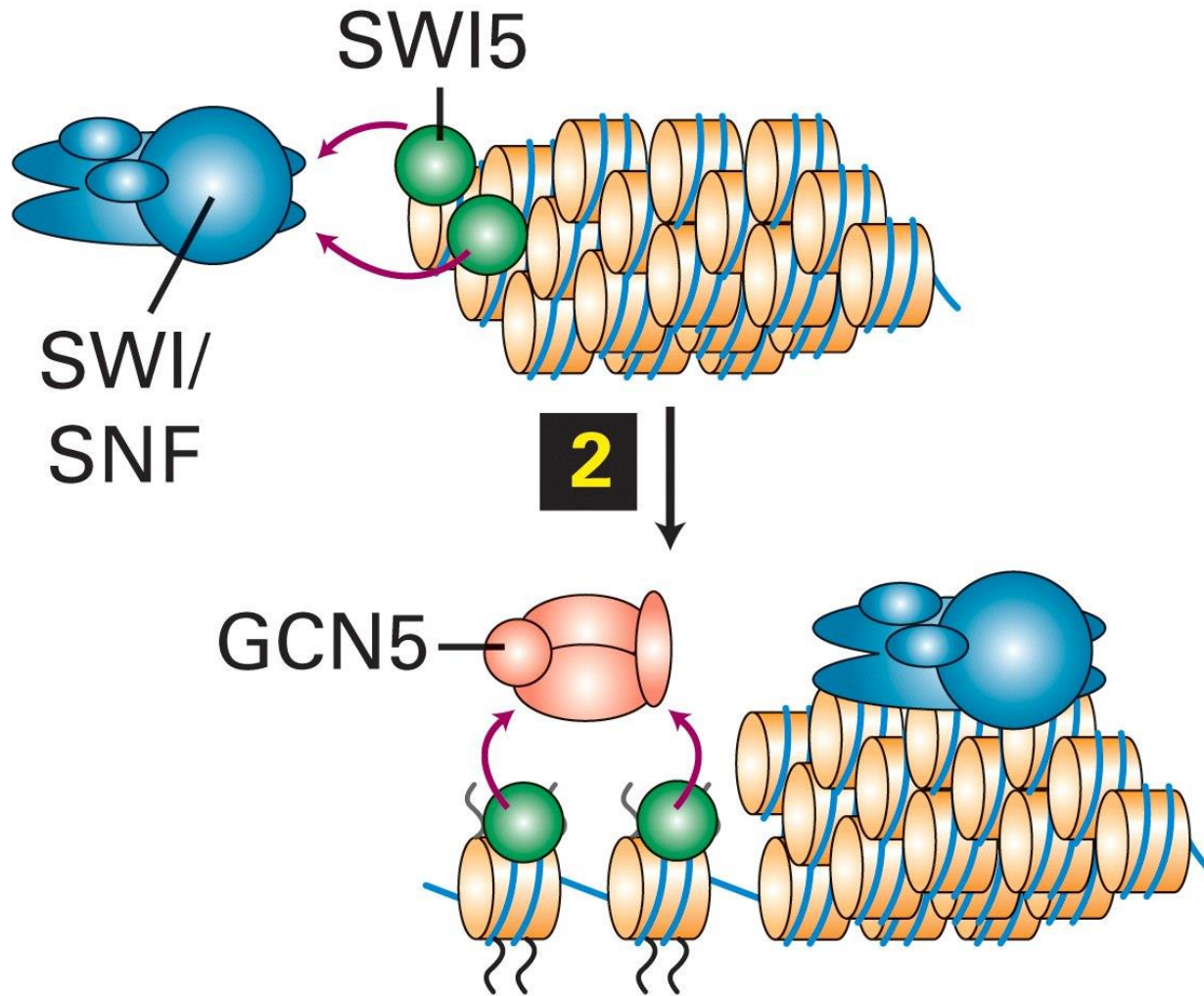

**SWI/SNF decondenses chromatin and exposes histon tails.
Histone acetylases (HAT) get recruited by SWI5**

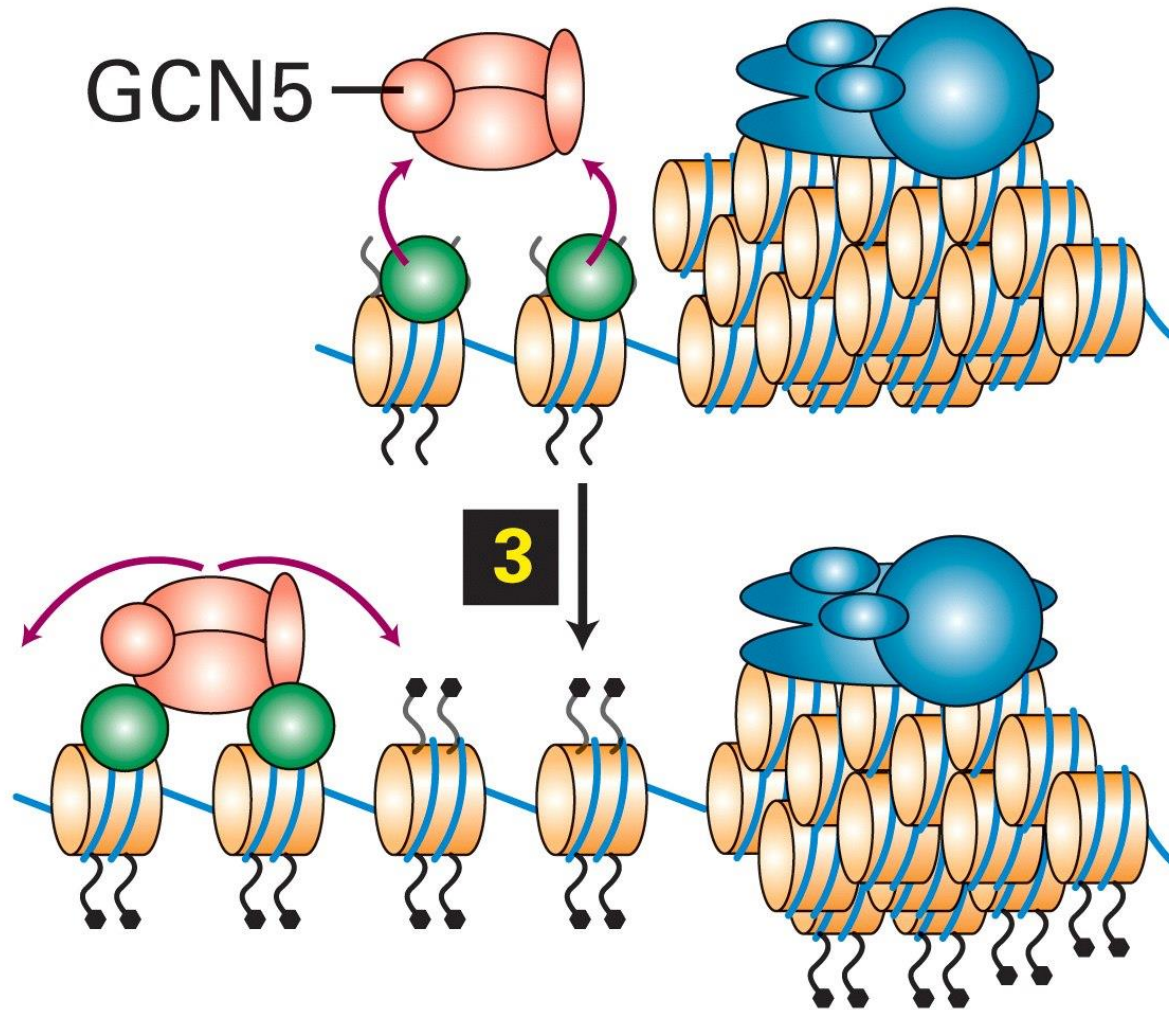

Histone tails get acetylated by GCN5

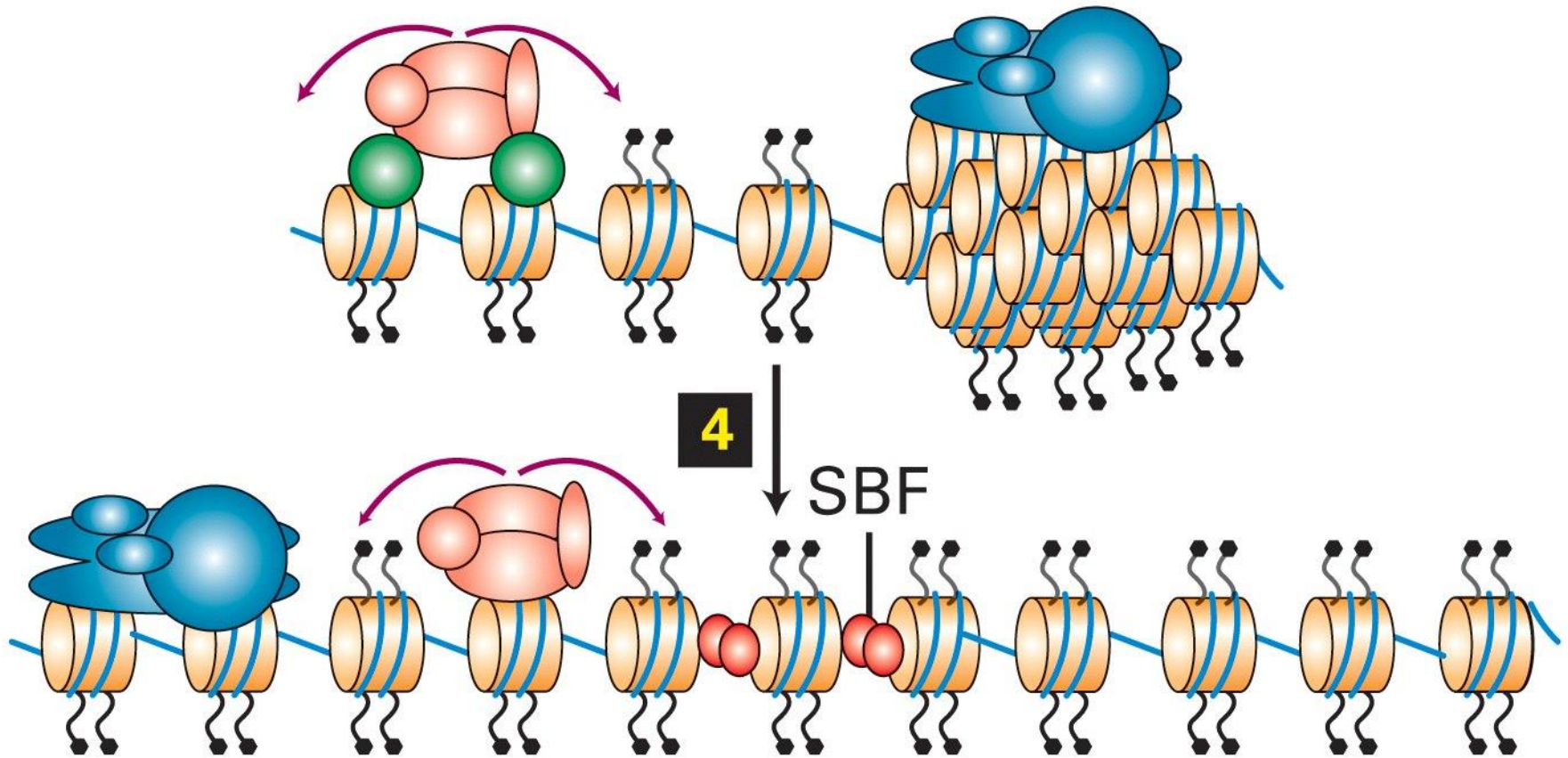

SBF activator gets bound to promoter proximal elements

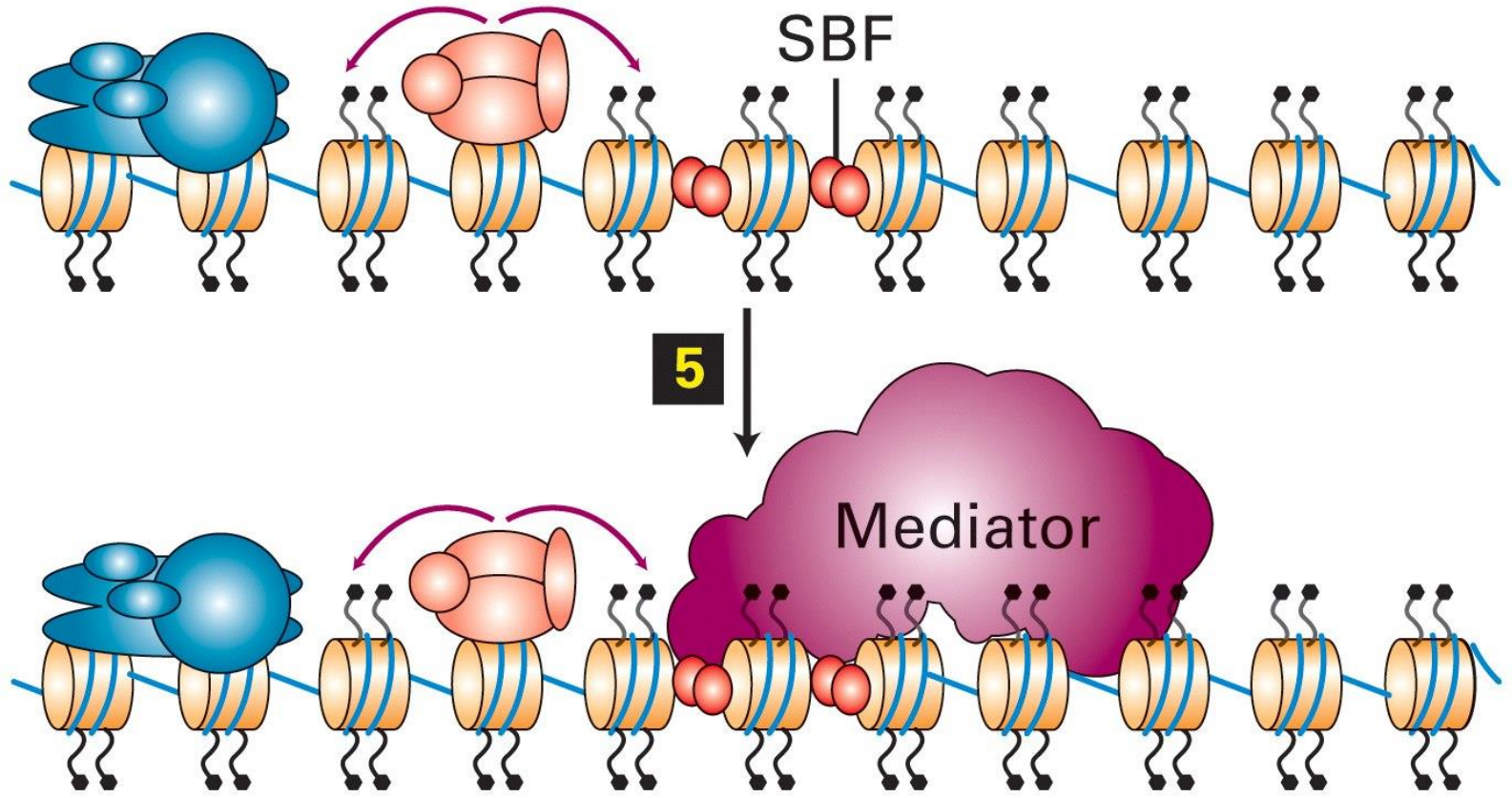

Mediator binds to SBF

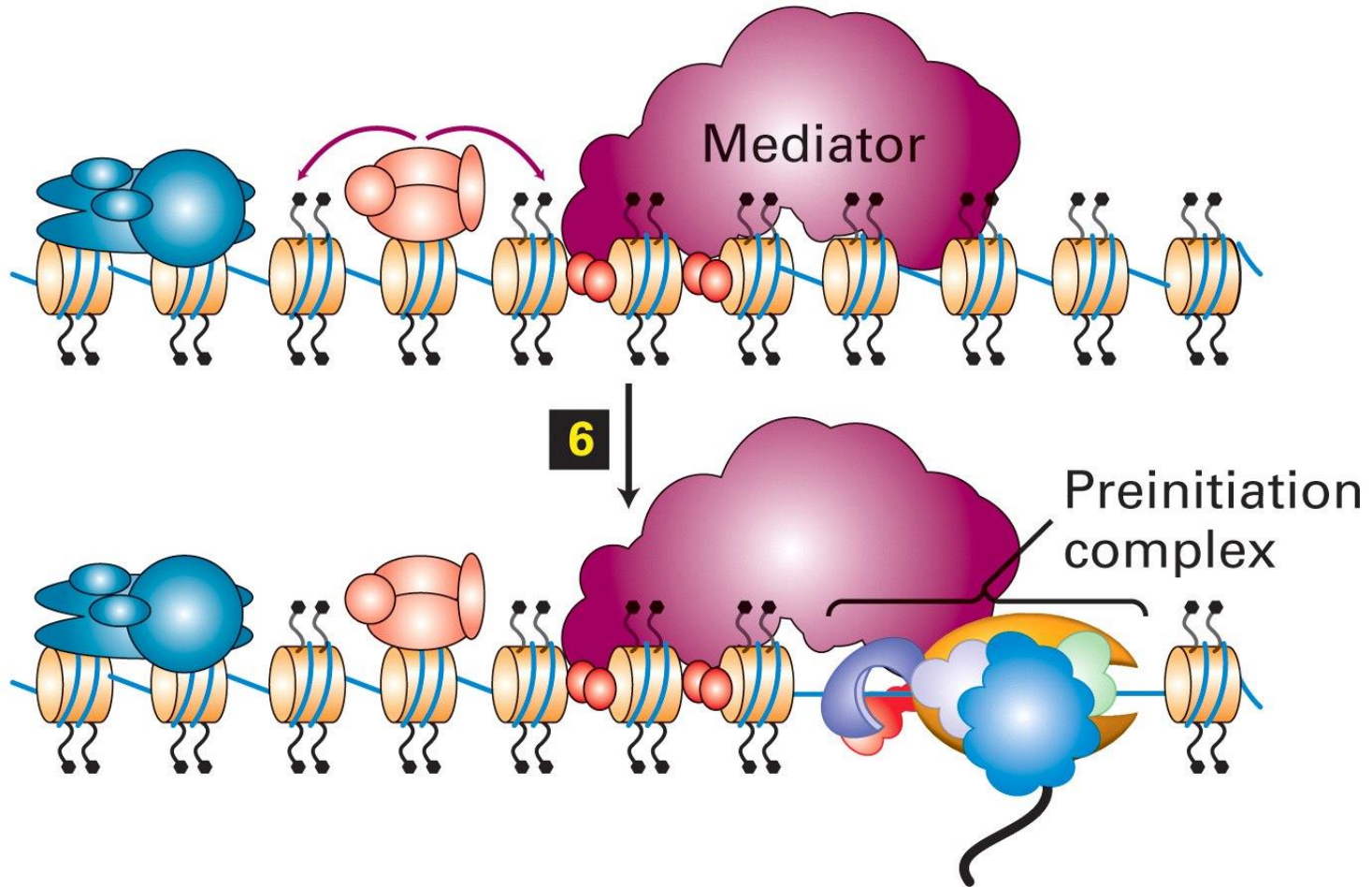

GTFs and pol II bind to TATA box element

Other modifications of histone

Methylation

Ubiquitination

Citrullination

Phosphorylation

Methylation of lysines **H3K4** and **H3K36** is correlated with **transcriptional activation**

Demethylation of **H3K4** is correlated with **silencing** of the genomic region.

Methylation of lysines **H3K9** and **H3K27** is correlated with **transcriptional repression**.

H3K9me3 is highly correlated with constitutive **heterochromatin**.

H3-Histone 3; H4-Histone 4; H2B-Histone 2B; K-Lysine

Type of modification	H3K4	H3K9	H3K14	H3K27	H3K79	H4K20	H2BK5
Mono-methylation	Activation	Activation		Activation	Activation	Activation	Activation
Di-methylation		Repression		Repression	Activation		
Tri-methylation	Activation	Repression		Repression	Act:n Rep:n		Repression
Acetylation		Activation		Activation			

Epigenetic control mechanisms

Methylation of DNA and histones

DNA methylation at CpG islands

A

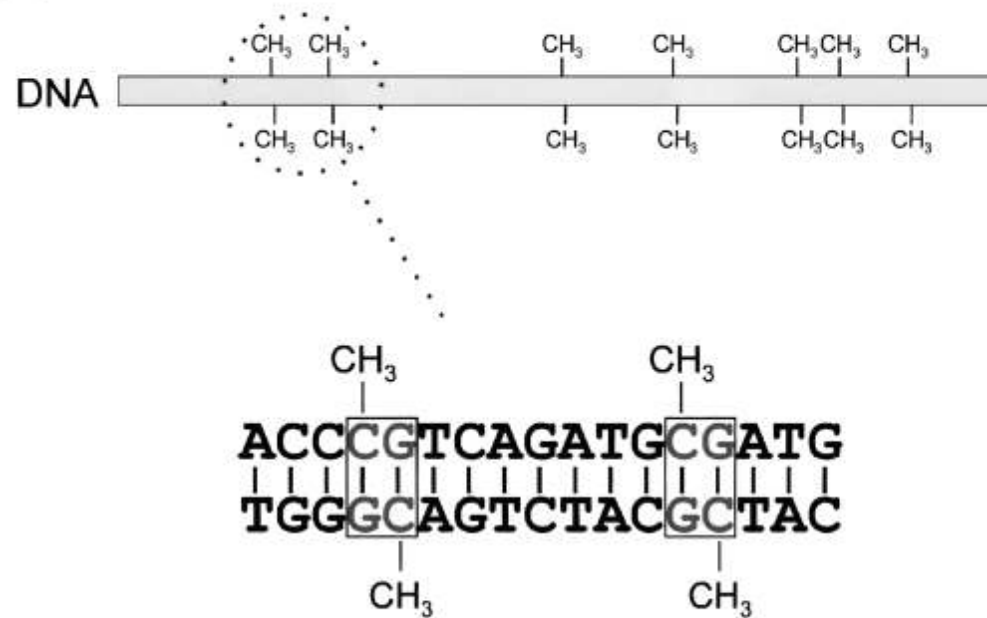

- DNMT – DNA methyltransferase
- SAM: S-adenosylmethionine

B

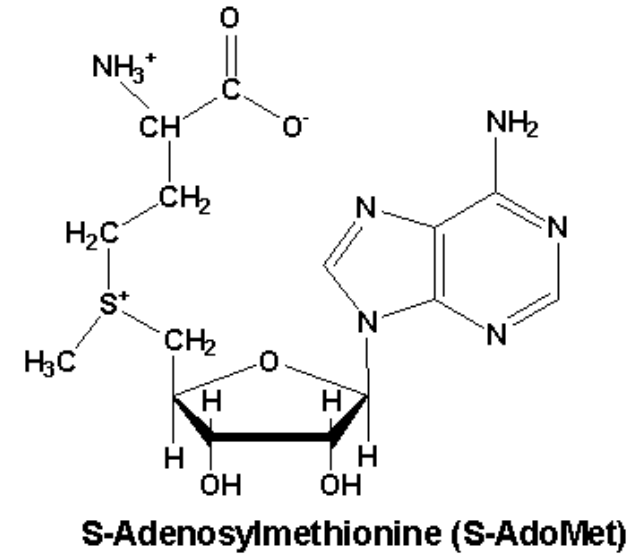
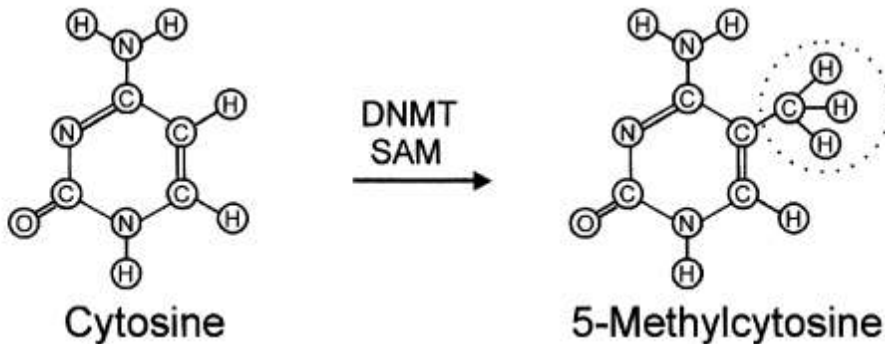

Methylation of CpG islands can block transcription by two distinct pathways:

- 1. Direct blocking of TFIID binding

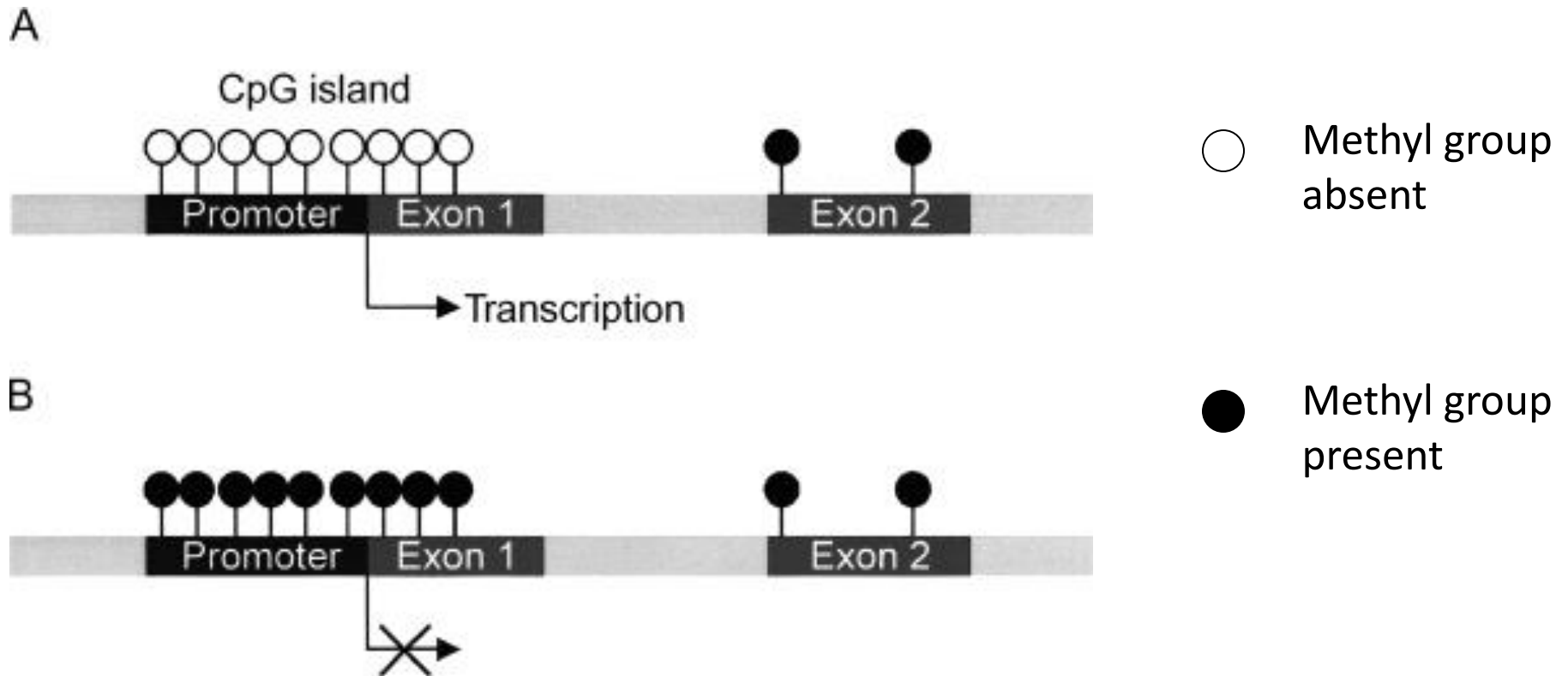

2. Recruitment of histone deacetylases

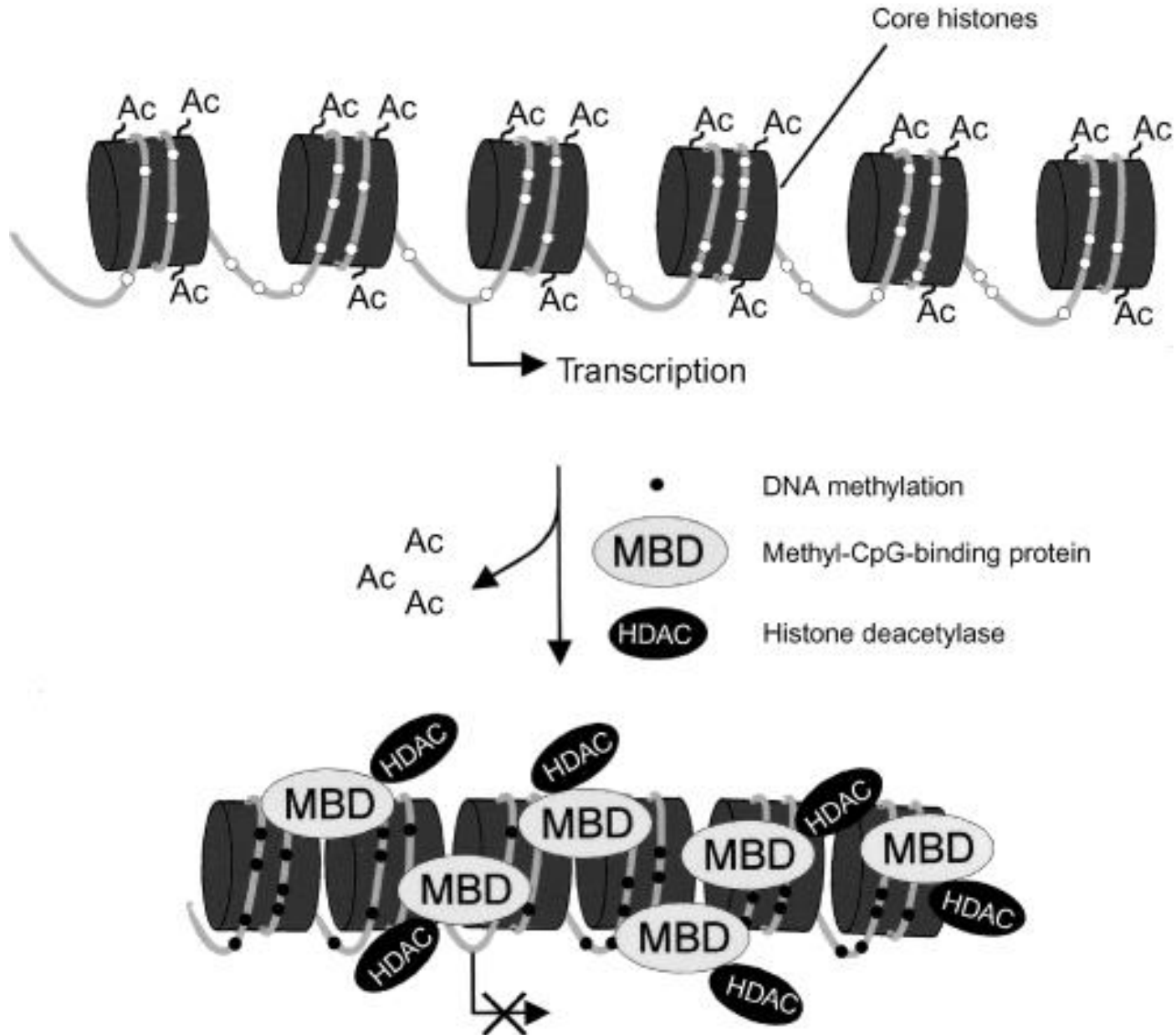

DNA methylation pattern can be inherited to daughter cells

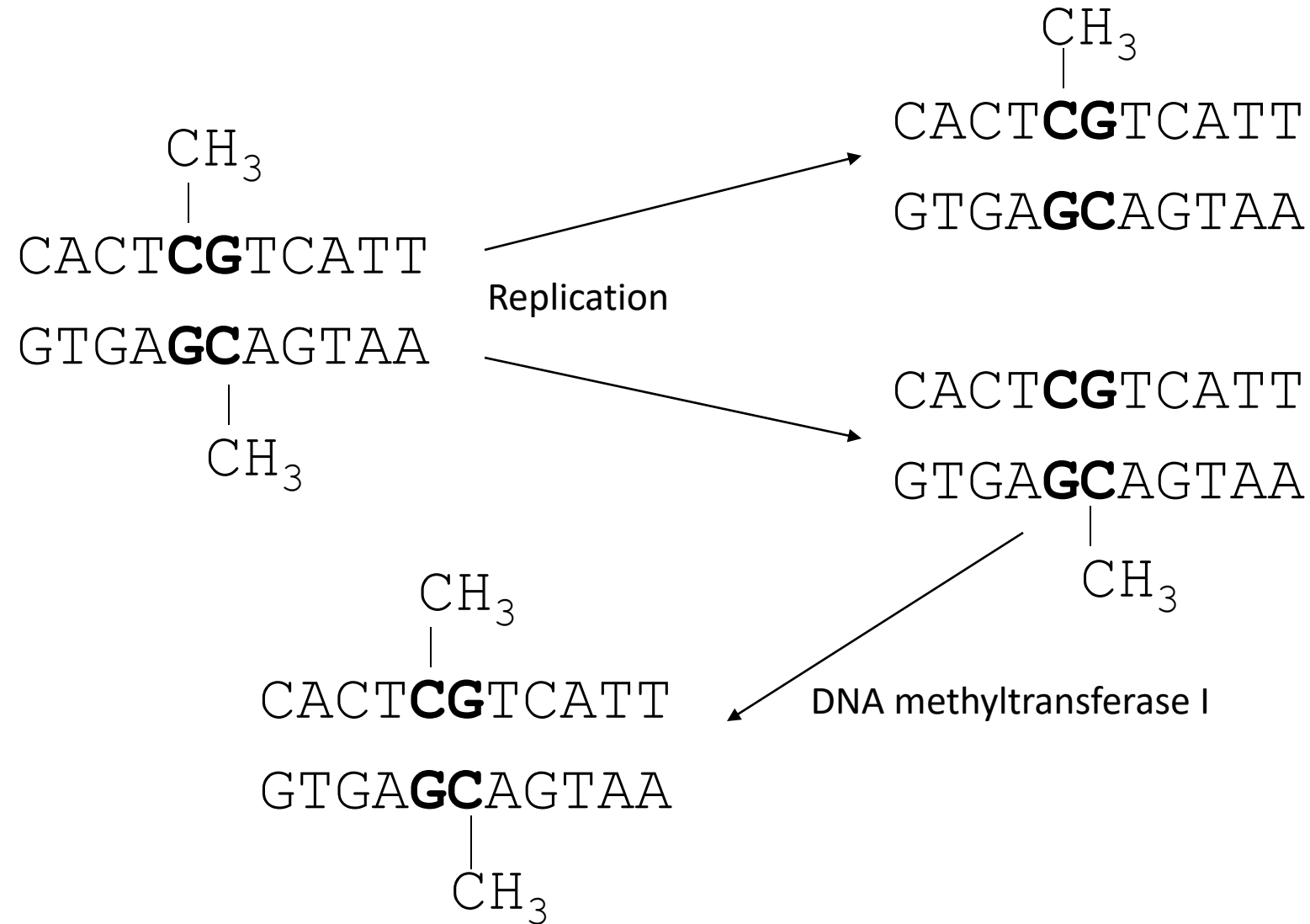

Histone modification pattern is also inherited to daughter cells through a poorly understood mechanism

- Since DNA methylation is at least sometimes linked to histone modification, conservation of histone pattern in daughter cells might be just a consequence of DNA methylation inheritance
- During replication, parental histones are randomly distributed to both daughter chromatids. Modified parental histones might serve as “nests” for modification of non-parental histones

Epigenetic inheritance has some consequences.....

- In early stages of embryo development the DNA is actively demethylated
- In cloned animals the demethylation pattern seems to be somewhat incomplete
- This might be a reason for observed abnormal development of cloned animals

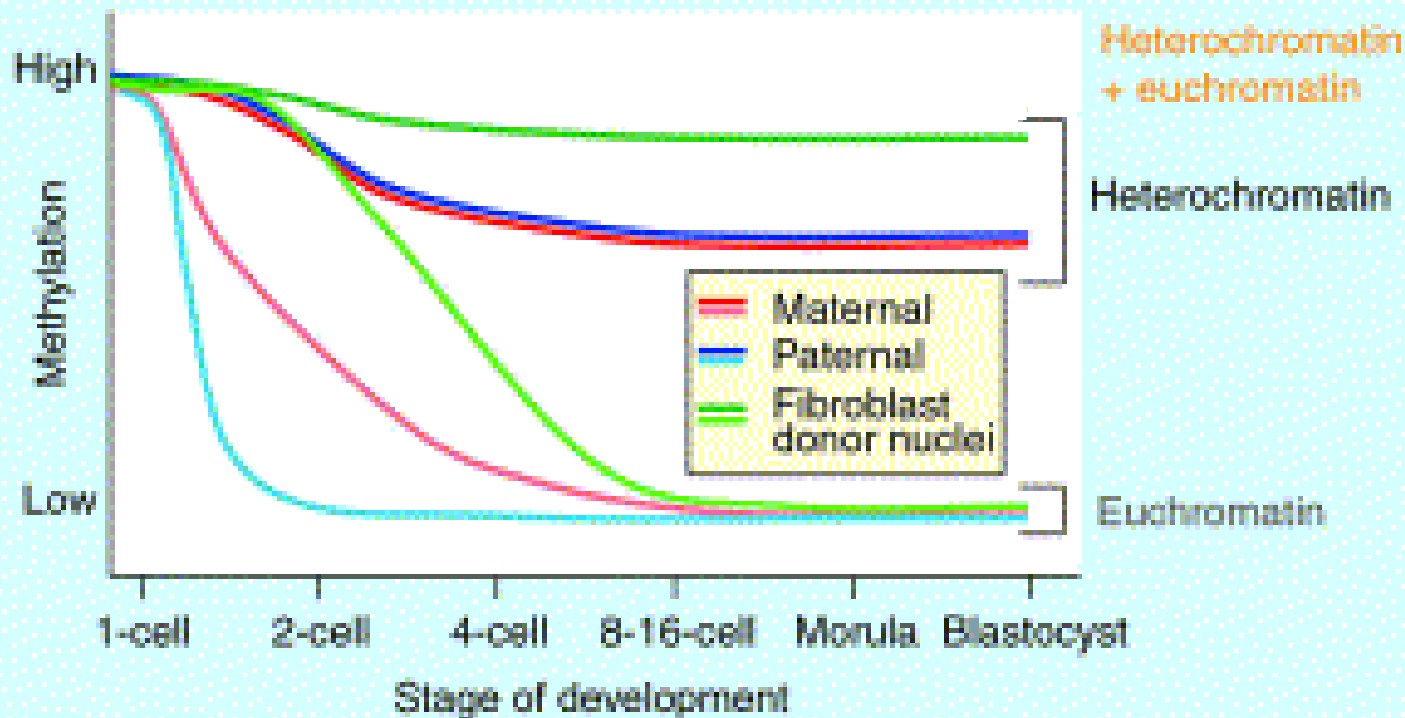

Regulation of transcription factor activity

- The activity of transcription factors can be regulated by:
 - (1) covalent modification (phosphorylation, acetylation, ubiquitination,)**
 - (2) by binding to ligands (nuclear receptors)**

Phosphorylation of transcription factors

Addition or removal of one or several phosphate groups on serine, threonine or tyrosine residues by a protein kinase or protein phosphatase.

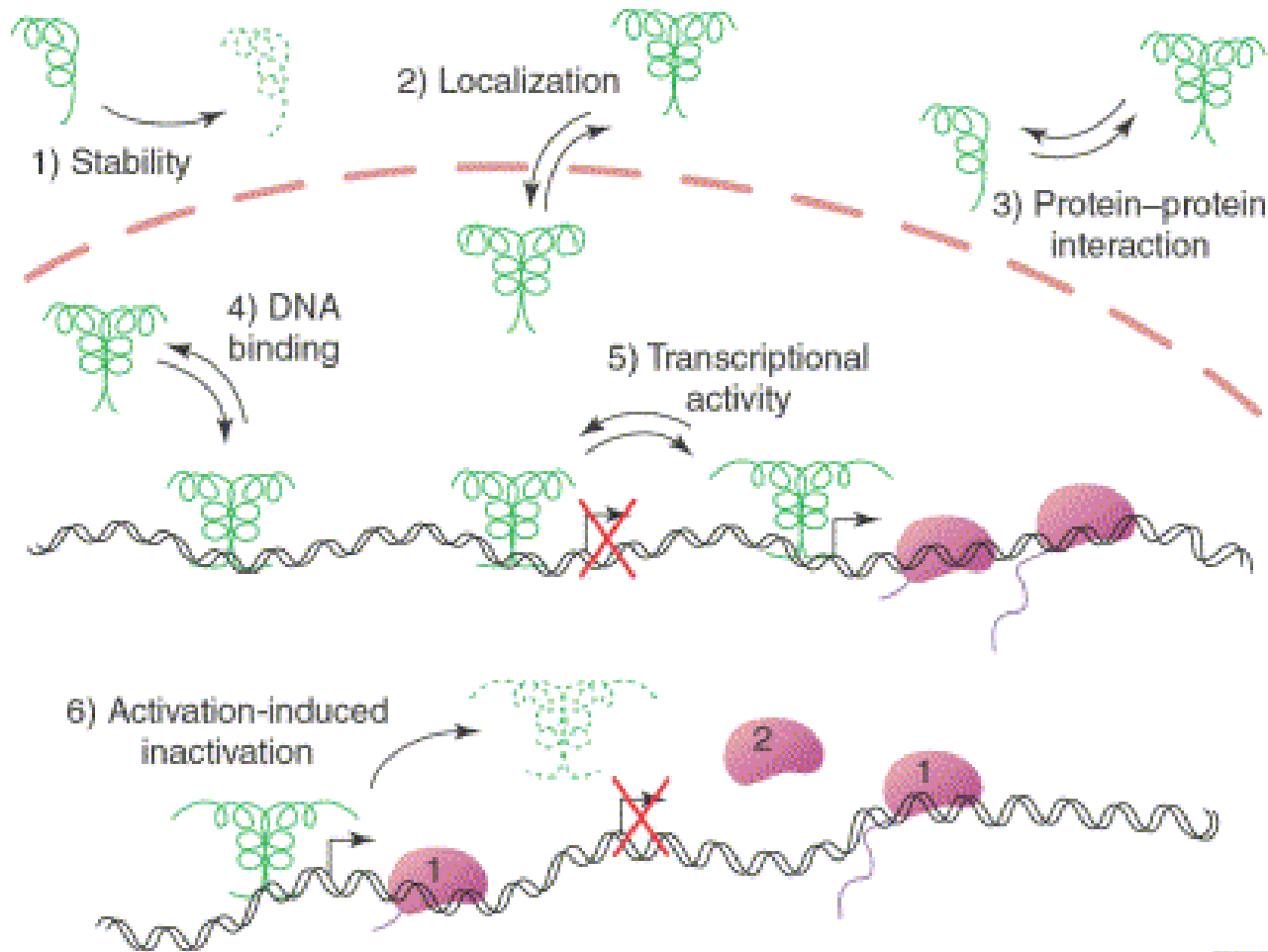

Protein p53

- p53 (**protein 53** kDa) is one of the most frequently cited biomolecules
- One of p53 functions is to act as a tumor suppressor, which prevents cell division under DNA damaging conditions as exposure to UV light, etc
- Knockout mice lacking p53 show normal development, but show predisposition to develop multiple tumors
- About half of all 6.5 million people, annually diagnosed for various forms of cancer have mutations in p53 gene

Normal conditions

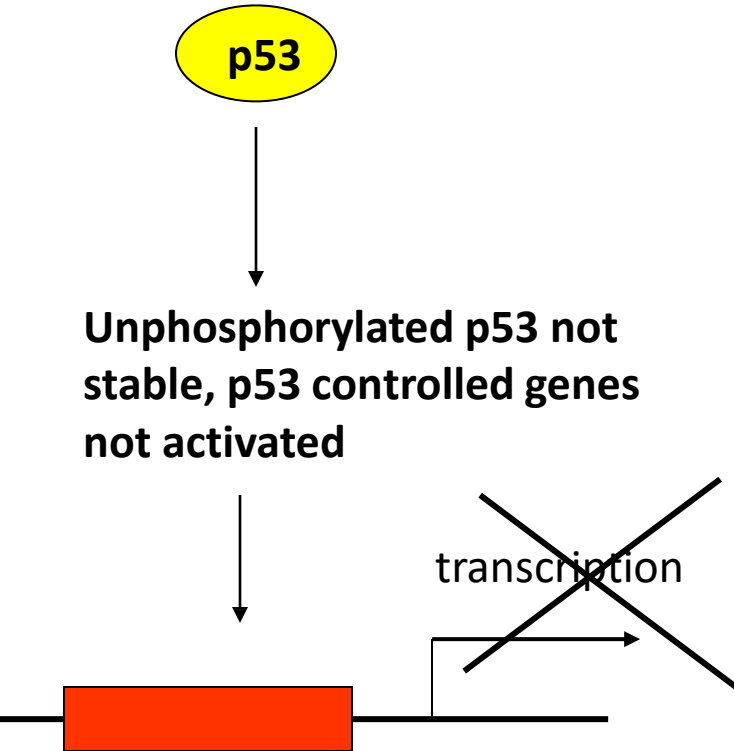

DNA-damaging conditions

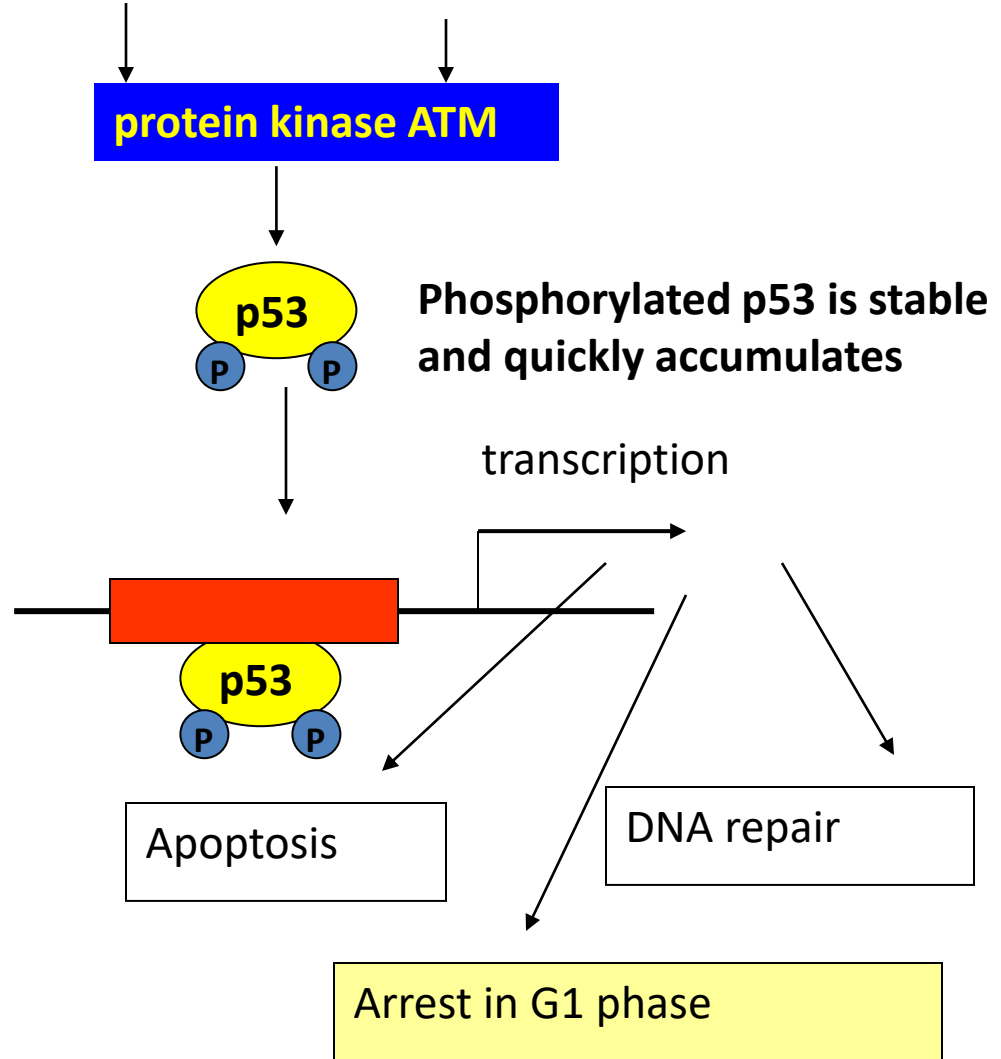

Most p53 cancer associated mutations occur in DNA binding regions

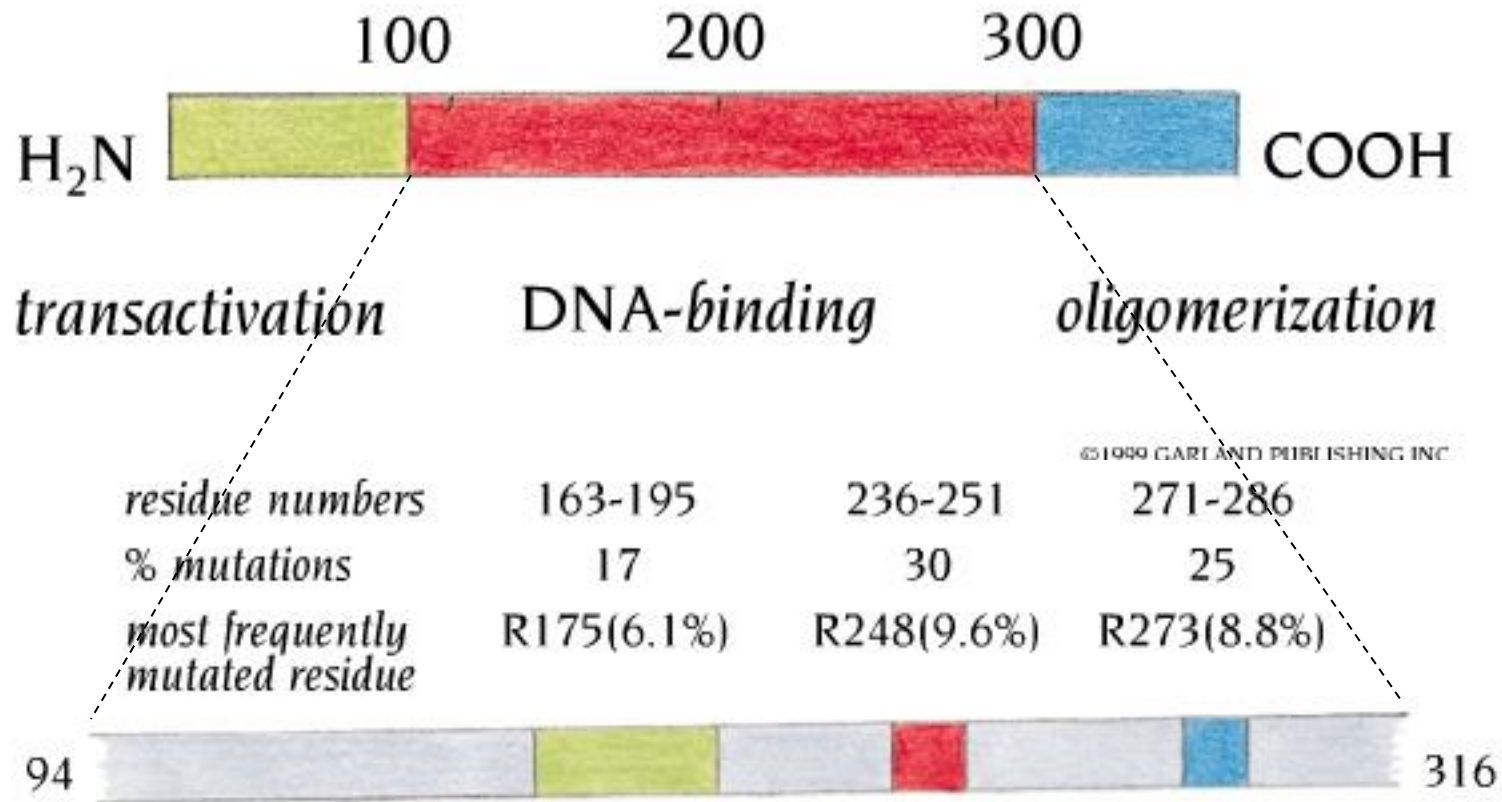

The 3D structure of p53 bound to DNA

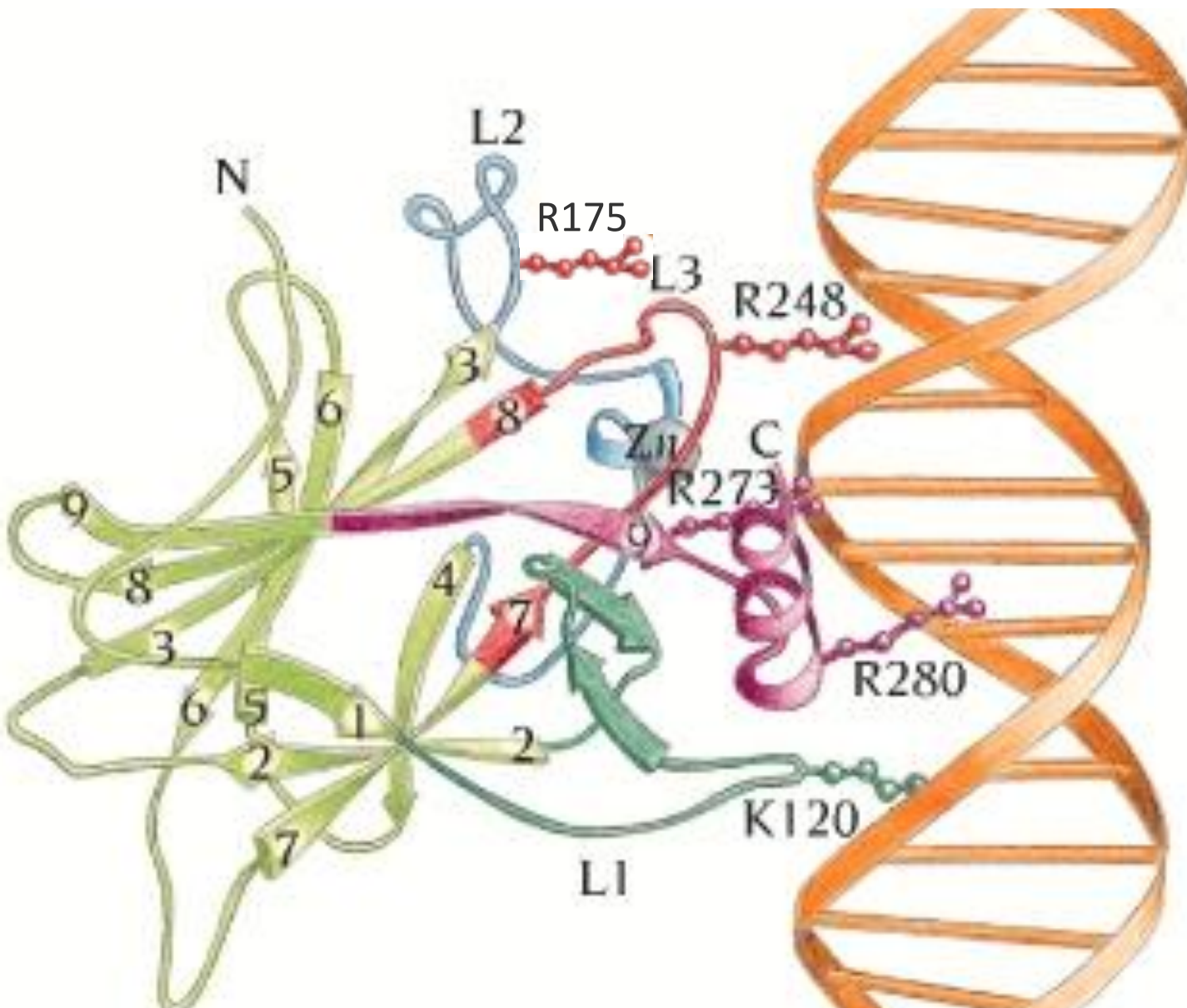

K120, R248, R273, R280 – binds directly to DNA. Mutation of any of those leads to decreased affinity

R175 – holds the L3 loop in the correct conformation. Mutation of R175 leads to unfunctional L3 loop

Some p53 cancer associated mutations occur in tetramerization region

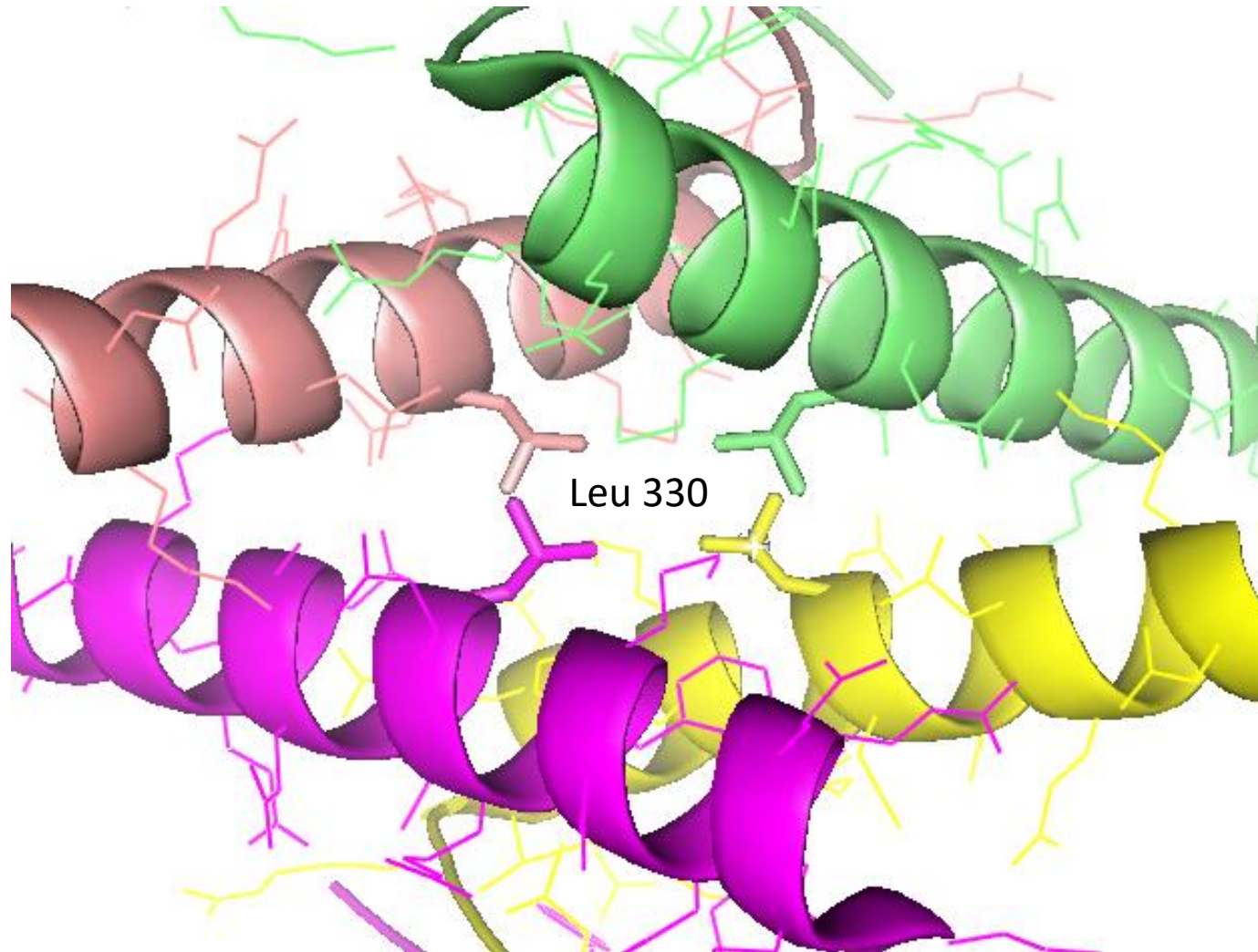

Nuclear receptors

- Transcription factors which get activated by lipid-soluble hormones
- Lipid-soluble hormones – small hydrophobic molecules capable to diffuse freely through plasma and nuclear membranes

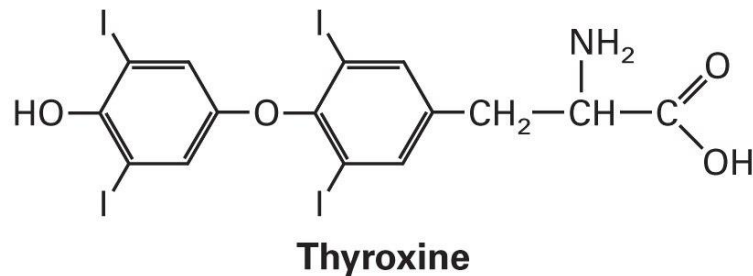
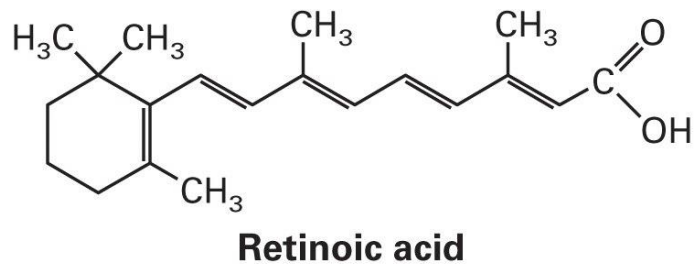
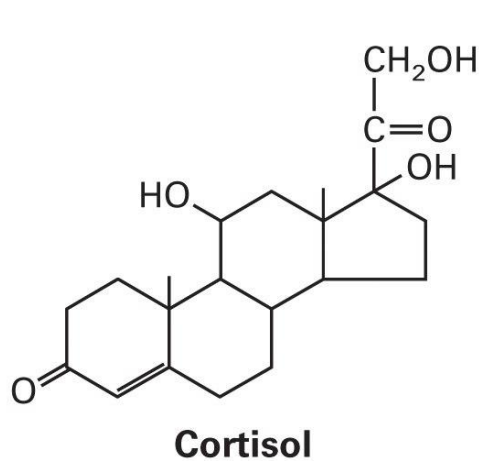

Action of homodimeric nuclear receptors

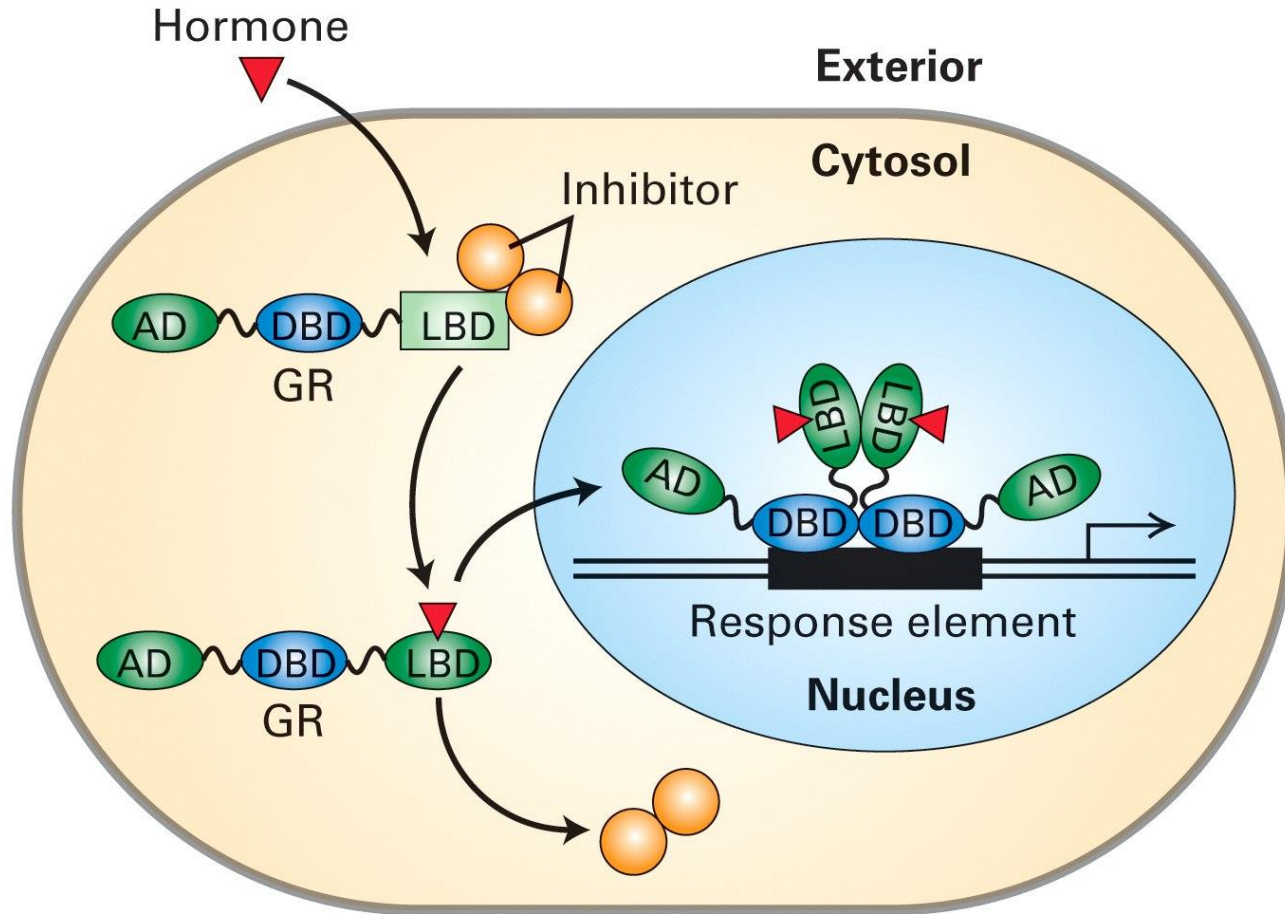

- In the absence of hormone, nuclear receptor is located in cytoplasm
- Upon binding to hormone, the nuclear receptor gets transported to nucleus, where it binds to the response element

Action of heterodimeric nuclear receptors

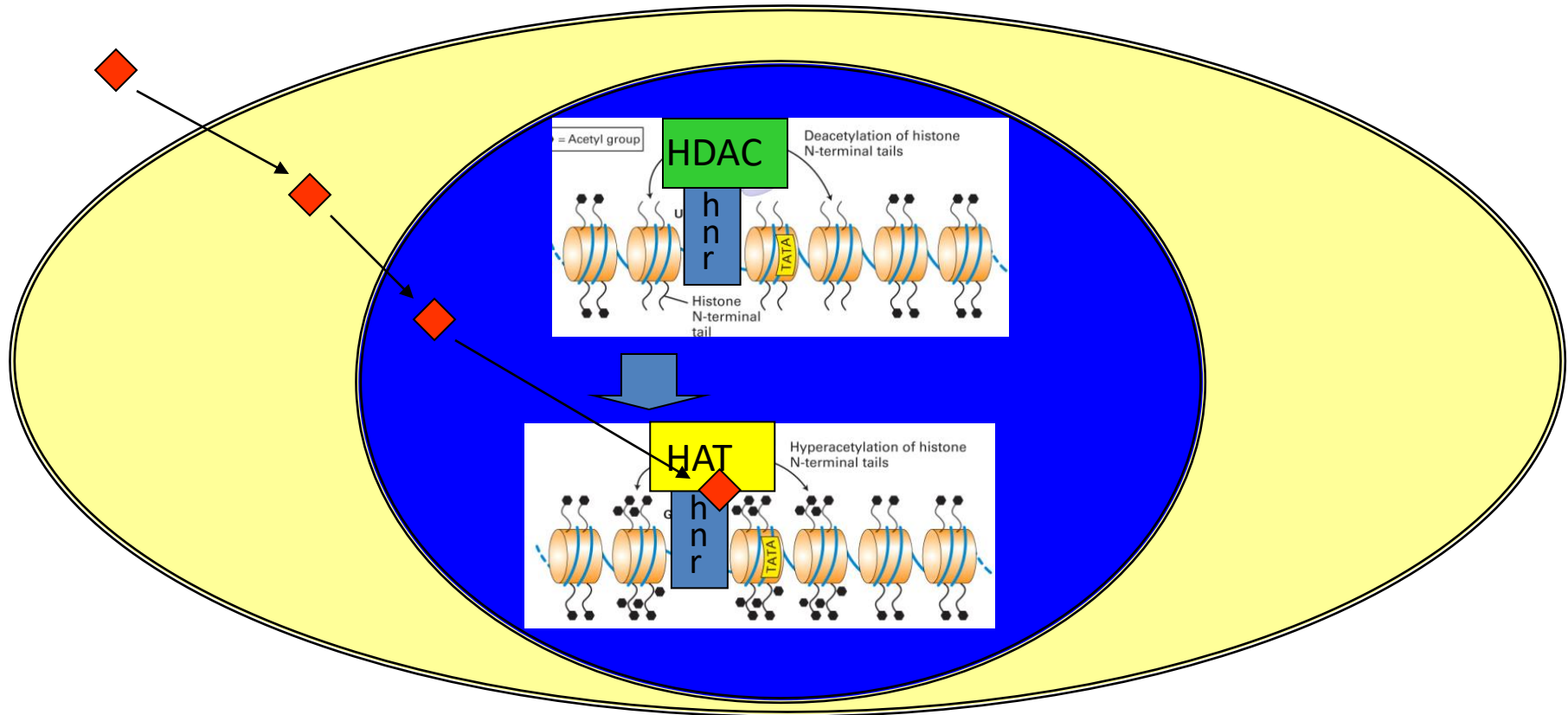

- In the absence of hormone, hnr binds to DNA response element and recruits histone deacetylases. Transcription is blocked.
- When hormone diffuses into the nucleus and binds to hnr, histone deacetylase gets released and histone acetylase binds instead. Transcription is activated.

Post-Transcriptional Gene Regulation

1. Gene Regulation of mRNA Processing

- Exon shuffling

- Alternative gene splicing

2. Gene Regulation of mRNA Editing

3. mRNA Longevity

4. mRNA Transport Control

5. RNA Interference (RNAi)

✿ **miRNA**

✿ **siRNA**



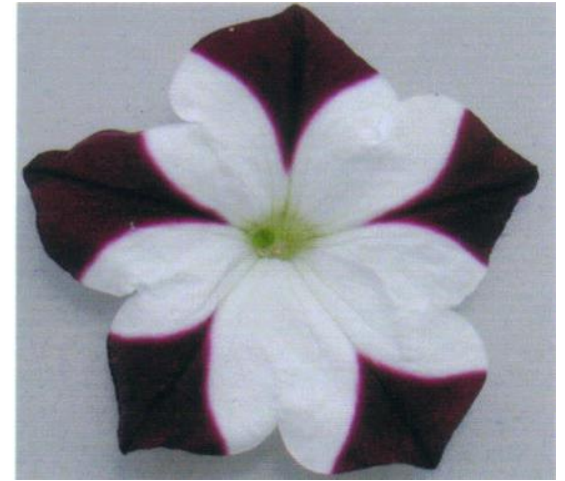

The left petunia is wild-type; the right petunias contain transgenes that induce suppression of both transgene and endogenous gene expression, giving rise to the unpigmented white areas of the flower.