

Trait	Bacteria	Archaea	Eukarya
Carbon linkage of lipids	Ester	<i>Ether</i>	Ester
Phosphate backbone of lipids	Glycerol-3-phosphate	<i>Glycerol-1-phosphate</i>	Glycerol-3-phosphate
Metabolism	Bacterial	Bacterial-like	Eukaryotic
Nucleus	No	No	Yes
Organelles	No	No	Yes
Spliceosomal introns	No	No	Yes
Telomeres	No	No	Yes
Chromosome shape	Mostly circular	Circular	Linear
DNA replication	Bacterial	Eukaryotic-like	Eukaryotic
Transcription	Bacterial	Eukaryotic-like	Eukaryotic
Translation	Bacterial	Eukaryotic-like	Eukaryotic

-----Macromolecules

- Are large molecules composed of smaller molecules
- Each cell has thousands of different kinds of macromolecules; the collection varies from one type of cell to another even in the same organism.
- The diversity of macromolecules in the living world is vast, and the possible variety is effectively limitless.

What is the basis for such diversity in life's polymers?

These molecules are made from only 40 to 50 common monomers and some others that occur rarely.

Building a huge variety of polymers from such a limited number of monomers is analogous to constructing hundreds of thousands of words from only 26 letters of the alphabet.

The key is arrangement-the particular linear sequence that the units follow.

Most biological polymers have many monomers.

Proteins, for example, are built from 20 kinds of amino acids arranged in chains that are typically hundreds of amino acids long.

The molecular logic of life is simple but elegant: Small molecules common to all organisms are ordered into unique macromolecules.

Despite this immense diversity, molecular structure and function can still be grouped roughly by class.

Each of the four major classes of large biological molecules:

Sugars, Lipids, Proteins, Nucleic Acids

For each class, the large molecules have emergent properties not found in their individual building blocks.

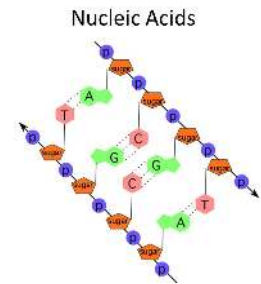
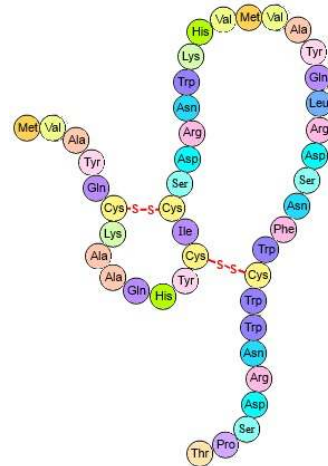
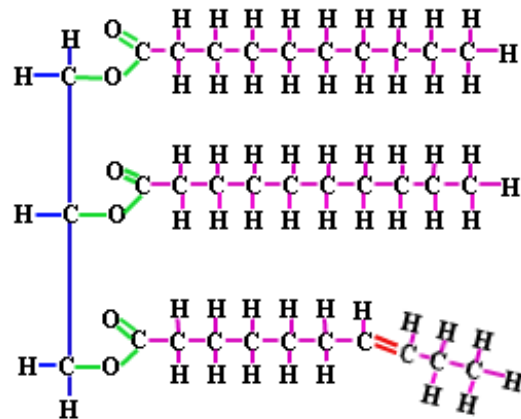
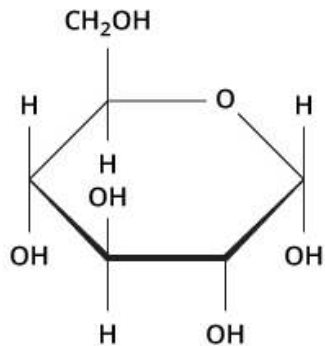

The Synthesis and Breakdown of Polymers

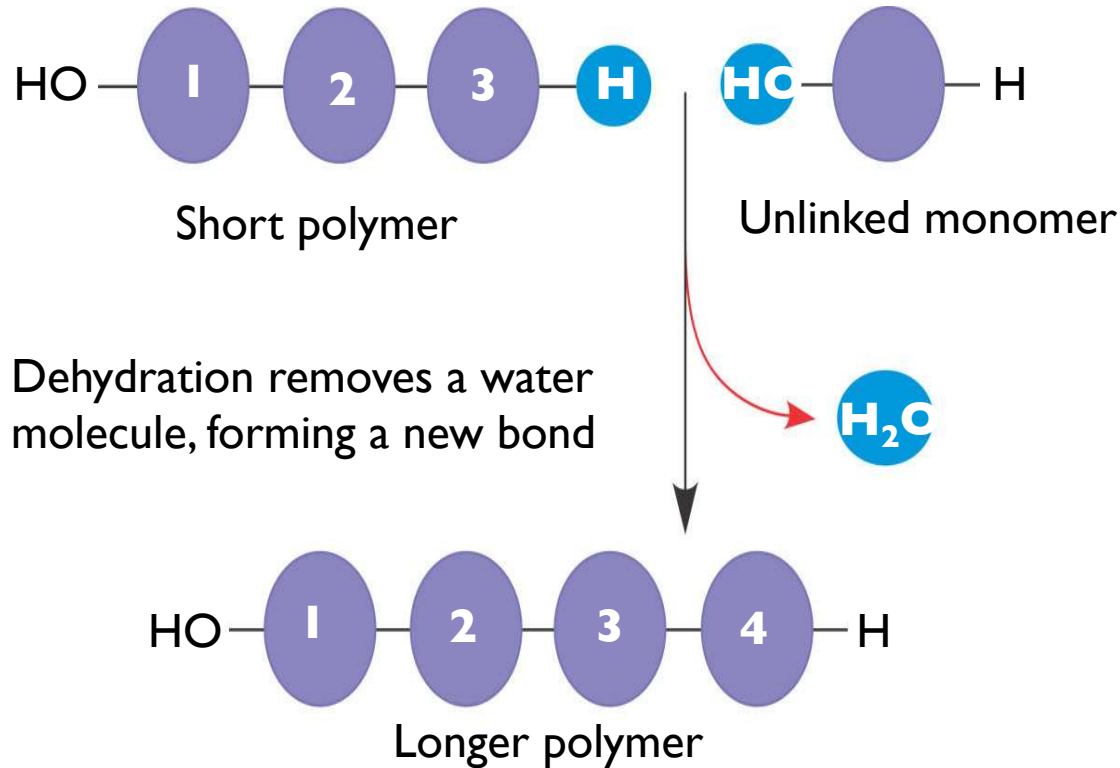

(a) Dehydration reaction in the synthesis of a polymer

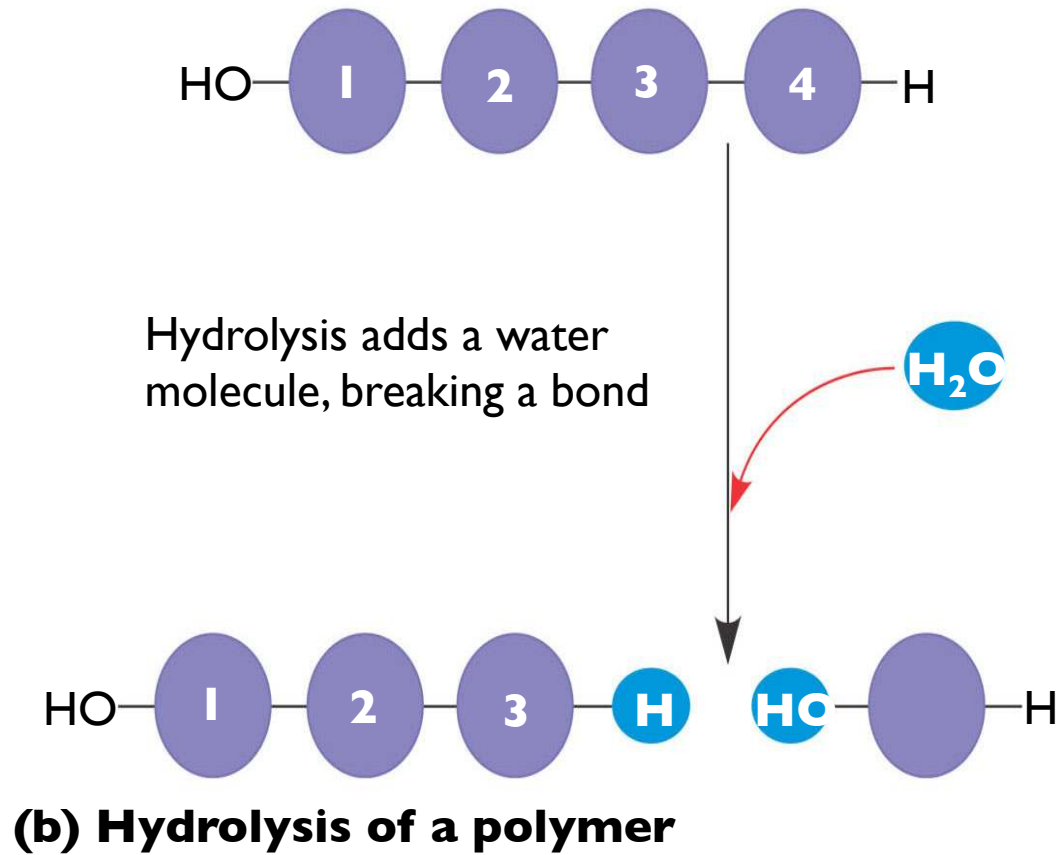
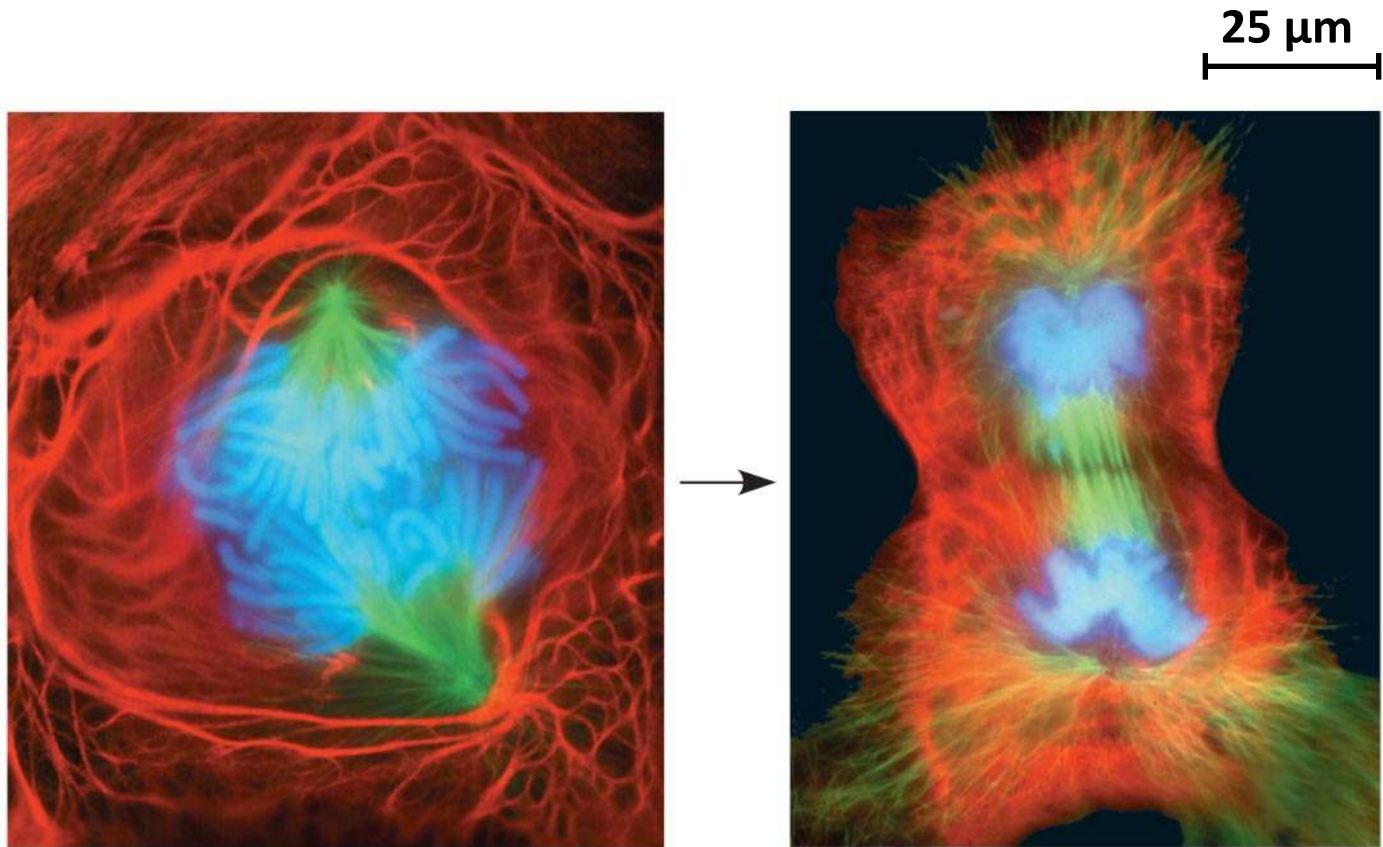

Figure 5.2B

Fig. 1-7



Copyright © 2008 Pearson Education, Inc., publishing as Pearson Benjamin Cummings.

Cell cycle analysis

Propidium iodide (PI) or 4',6'-diamidino-2-phenylindole (DAPI). Three major phases of the cycle (G₁ vs S vs G₂/M)

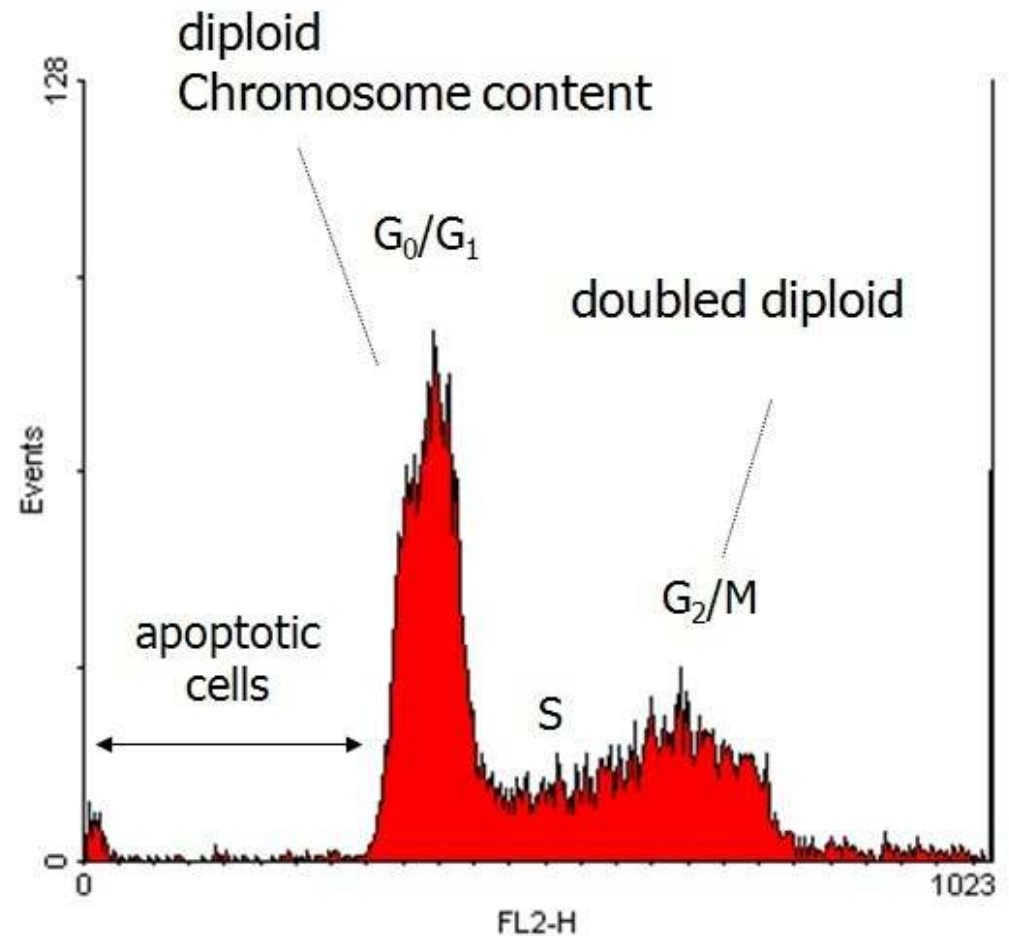
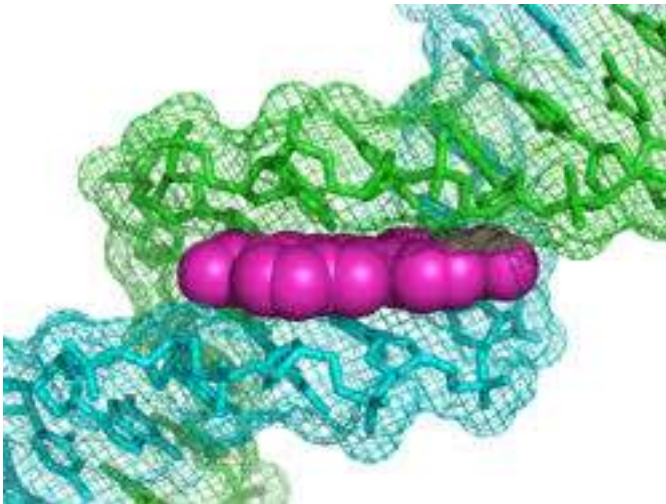

Eukaryotic vs Prokaryotic cells

- A **eukaryotic cell** has membrane-enclosed organelles, the largest of which is usually the nucleus
- By comparison, a **prokaryotic cell** is simpler and usually smaller, and does not contain a nucleus or other membrane-enclosed organelles
- Bacteria and Archaea are prokaryotic; plants, animals, fungi, and all other forms of life are eukaryotic

Fig. 1-8

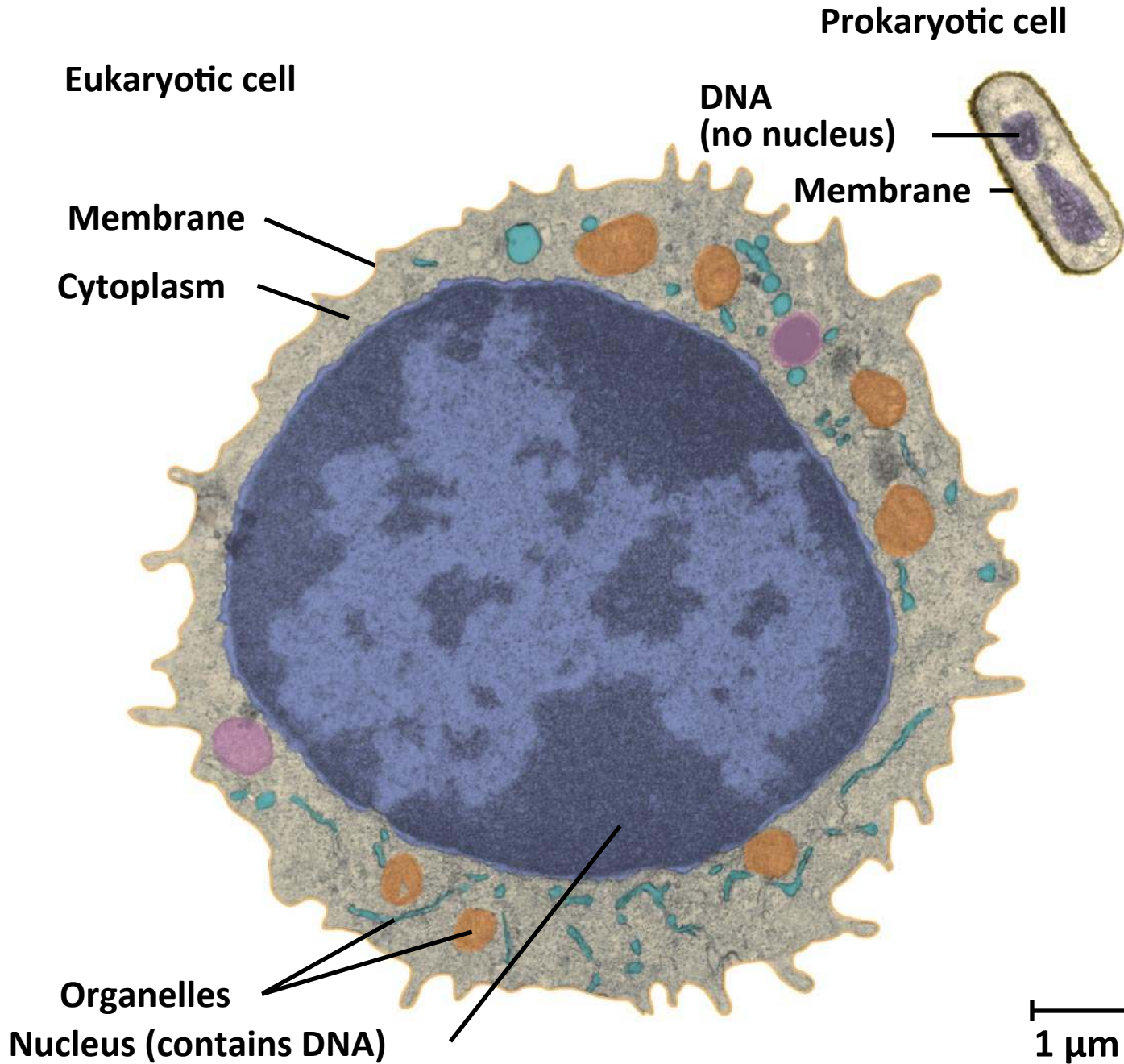

The continuity of life is based on heritable **information** in the form of DNA

- Chromosomes contain most of a cell's genetic material in the form of **DNA** (deoxyribonucleic acid)
- DNA is the substance of genes
- **Genes** are the units of inheritance that transmit information from parents to offspring

DNA Structure and Function

- Each chromosome has one long DNA molecule with hundreds or thousands of genes
- DNA is inherited by offspring from their parents
- DNA controls the development and maintenance of organisms

Fig. 1-9

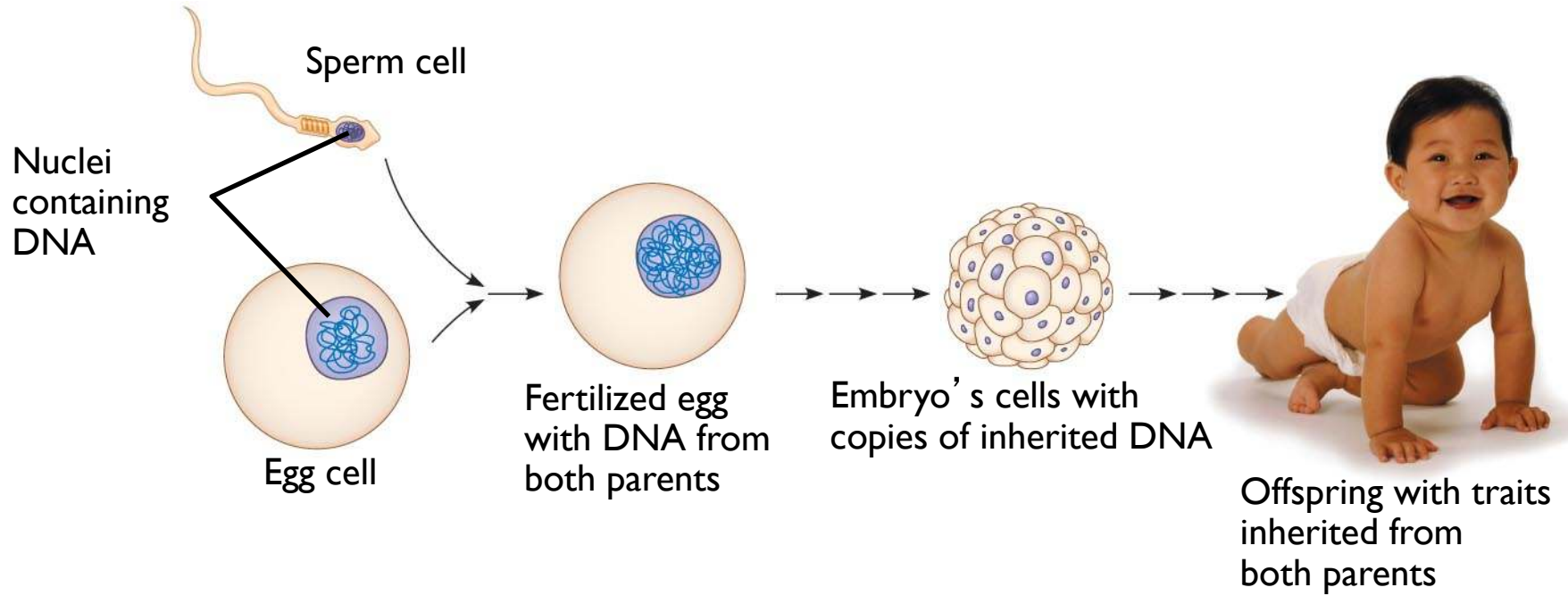

-
- Each DNA molecule is made up of two long chains arranged in a double helix
 - Each link of a chain is one of four kinds of chemical building blocks called nucleotides

Fig. 1-10

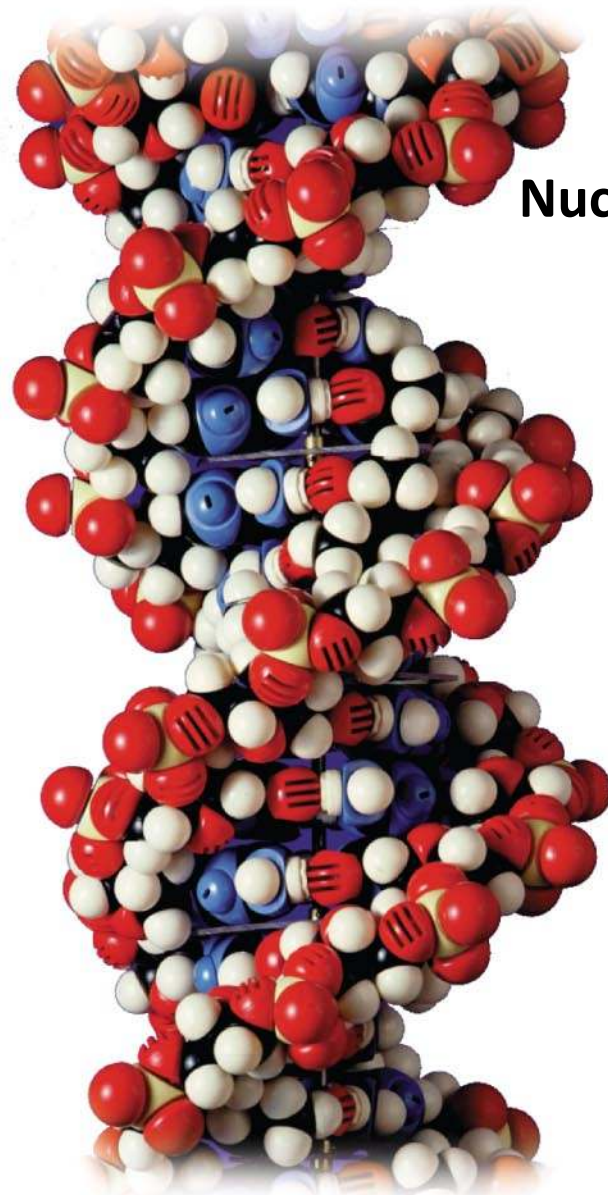
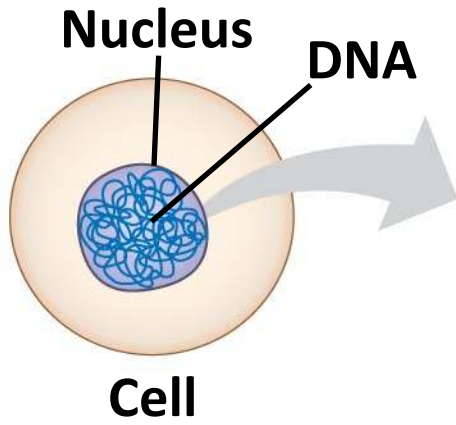

(a) DNA double helix

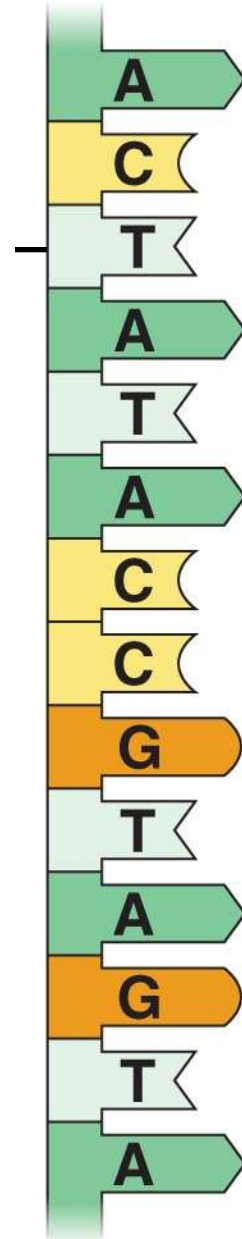

(b) Single strand of DNA

How did DNA:

1. Store information?

2. Duplicate itself easily?

These questions would be answered
by discovering DNA's structure

AMAZING DNA FACTS...

- **DNA from a single human cell extends in a single thread for almost 2 meters long!!!**
- **It contains information equal to some 600,000 printed pages of 500 words each!!!**
(a library of about 1,000 books)



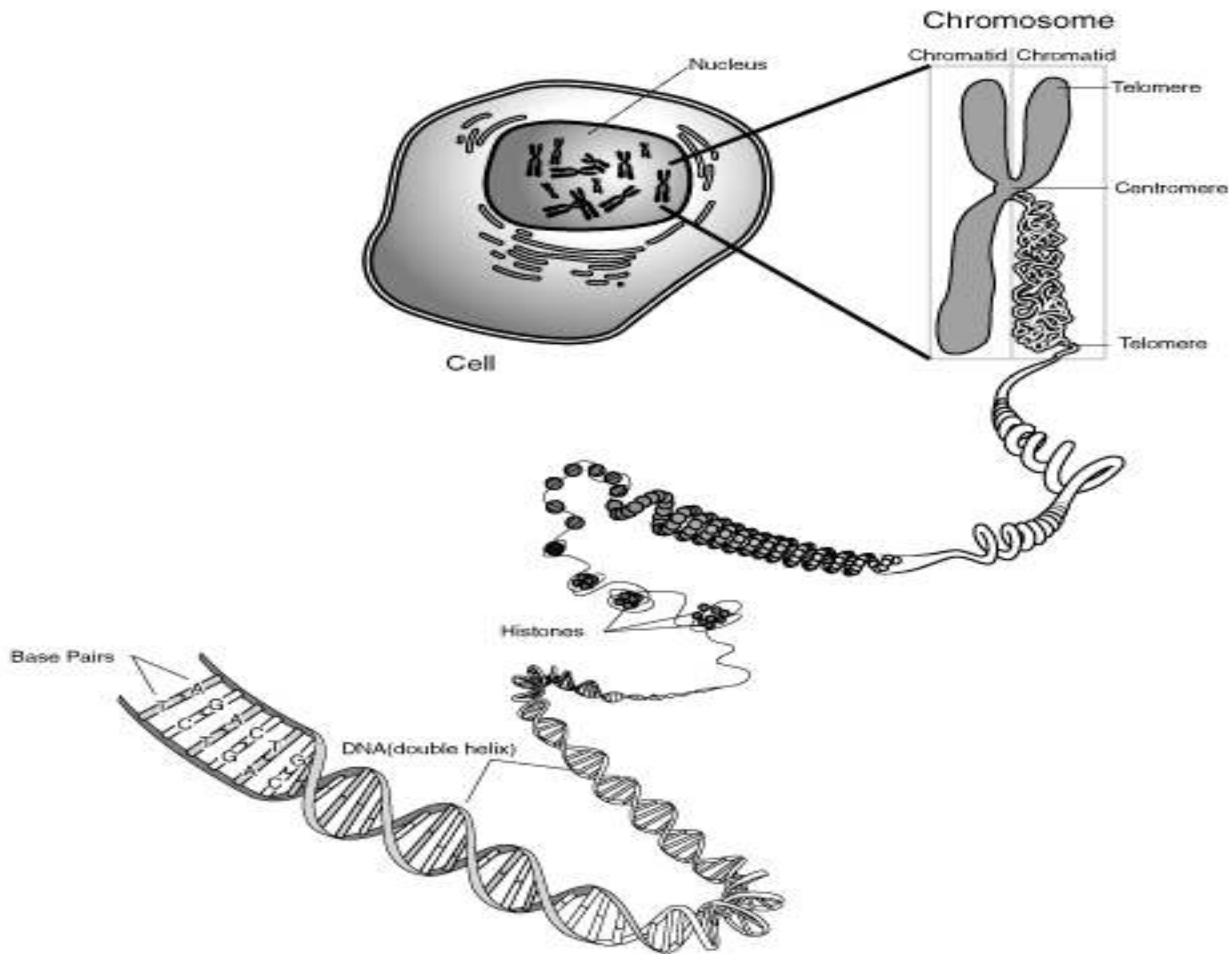

Building blocks

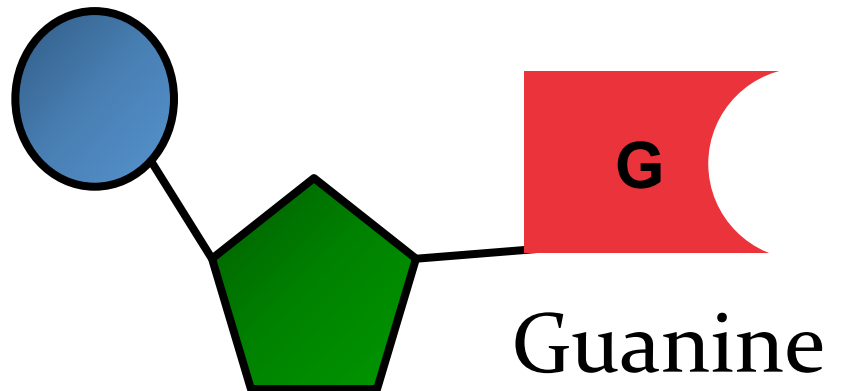
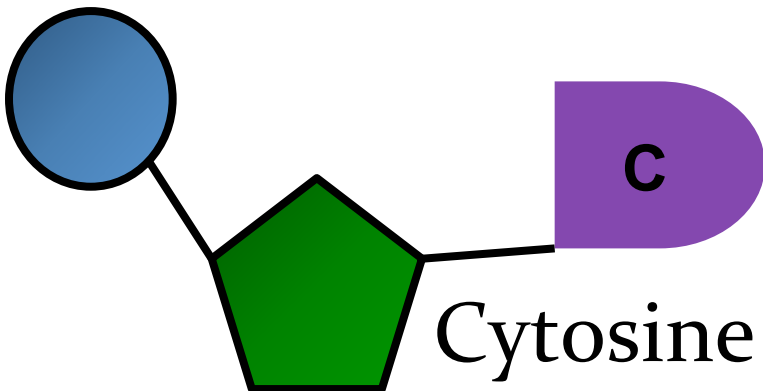
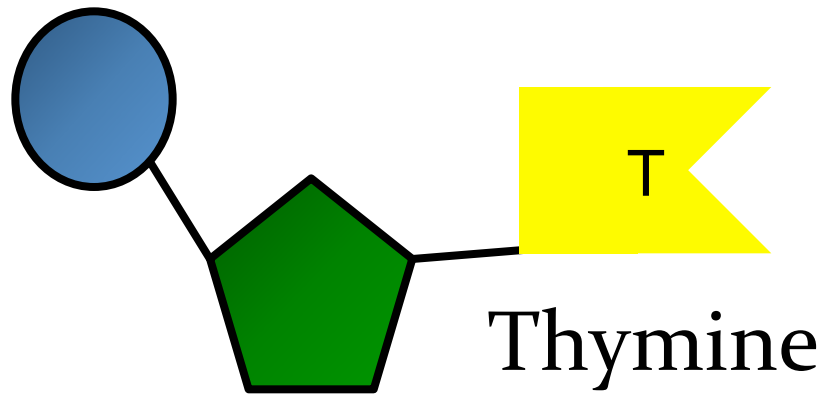
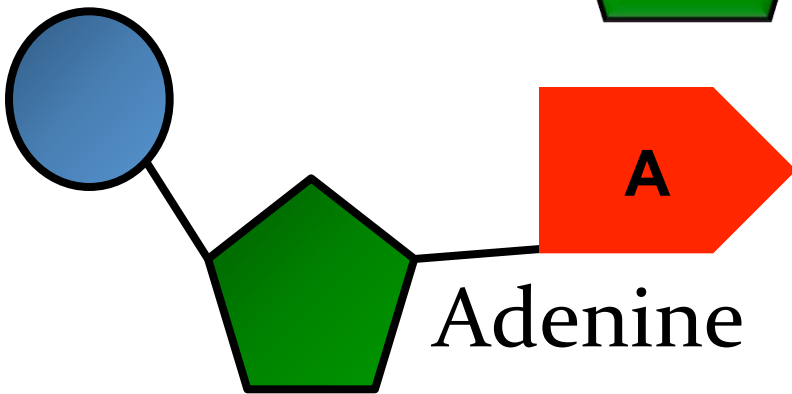
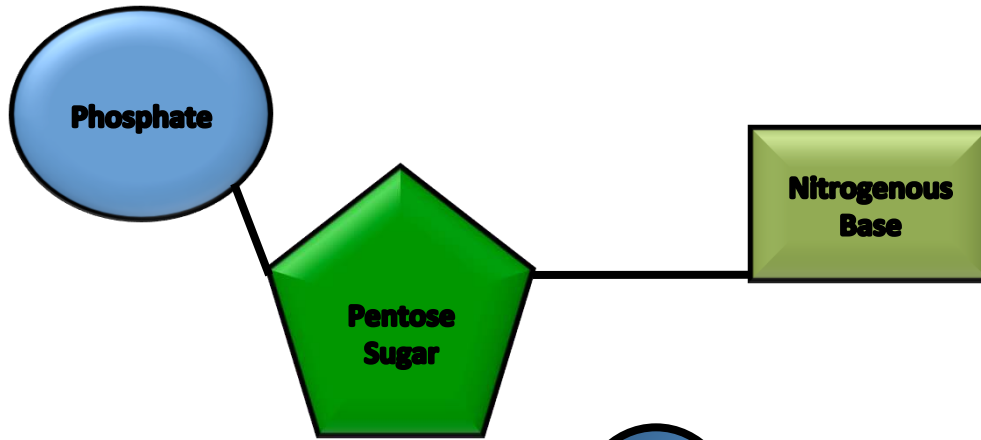

DNA Nucleotide

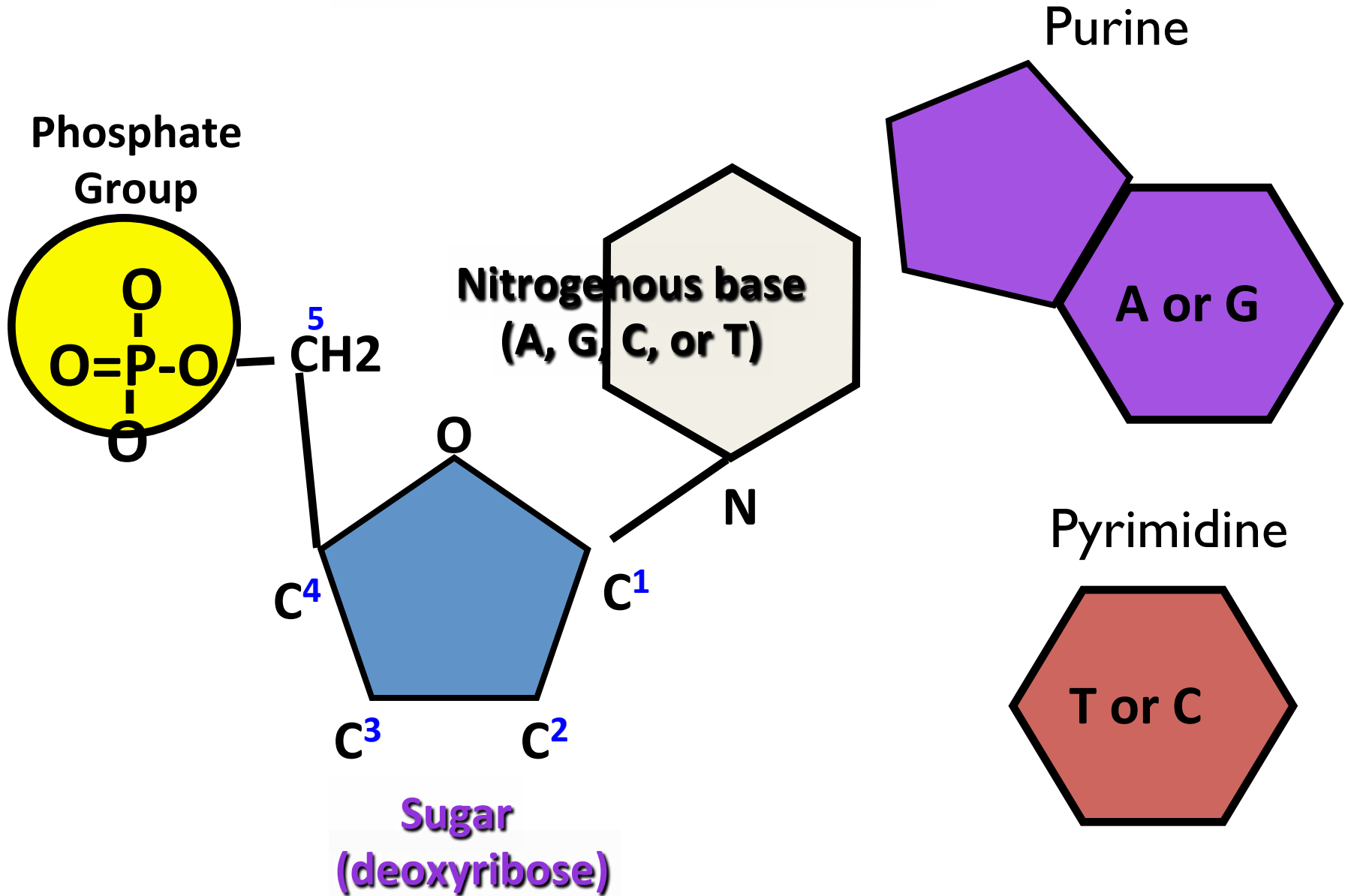

- charge

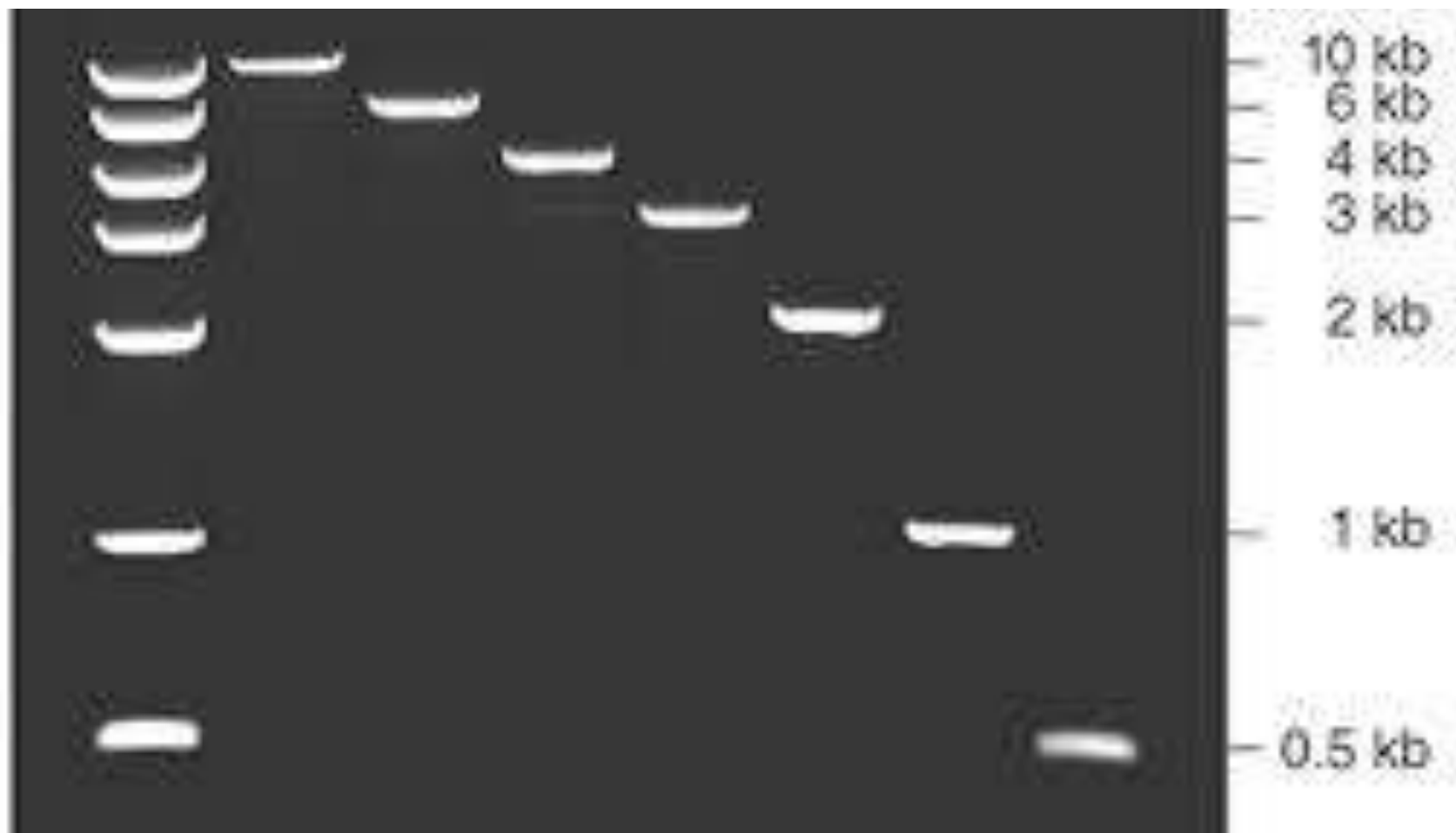

+ charge

DNA Double Helix

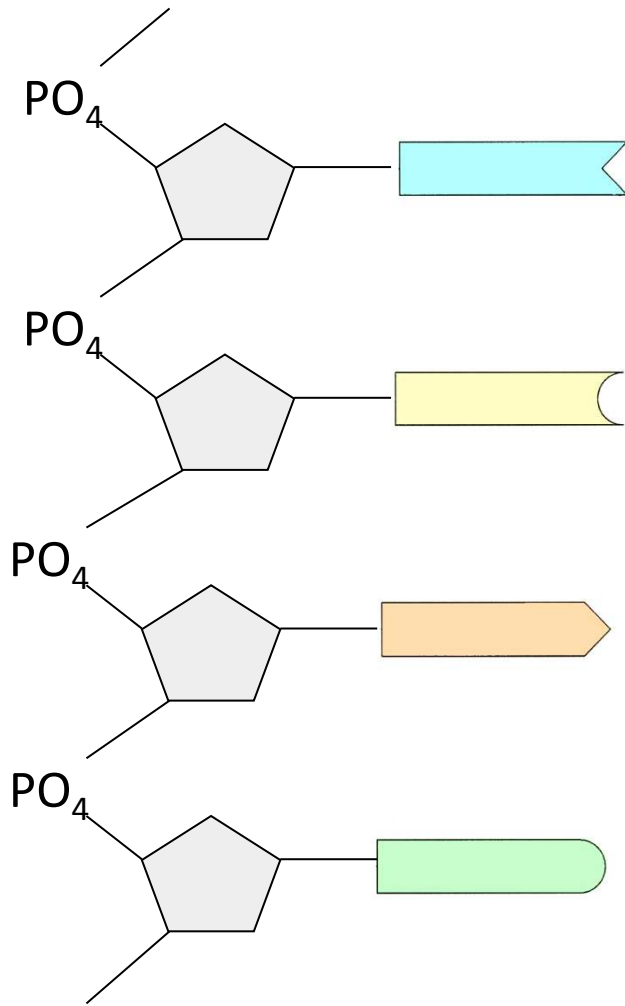

sugar-phosphate + bases
backbone

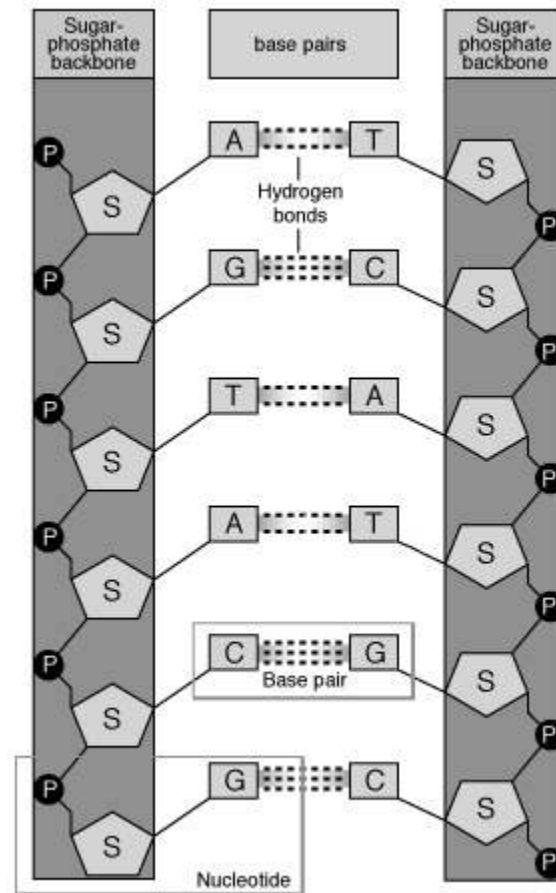

DNA's Structure

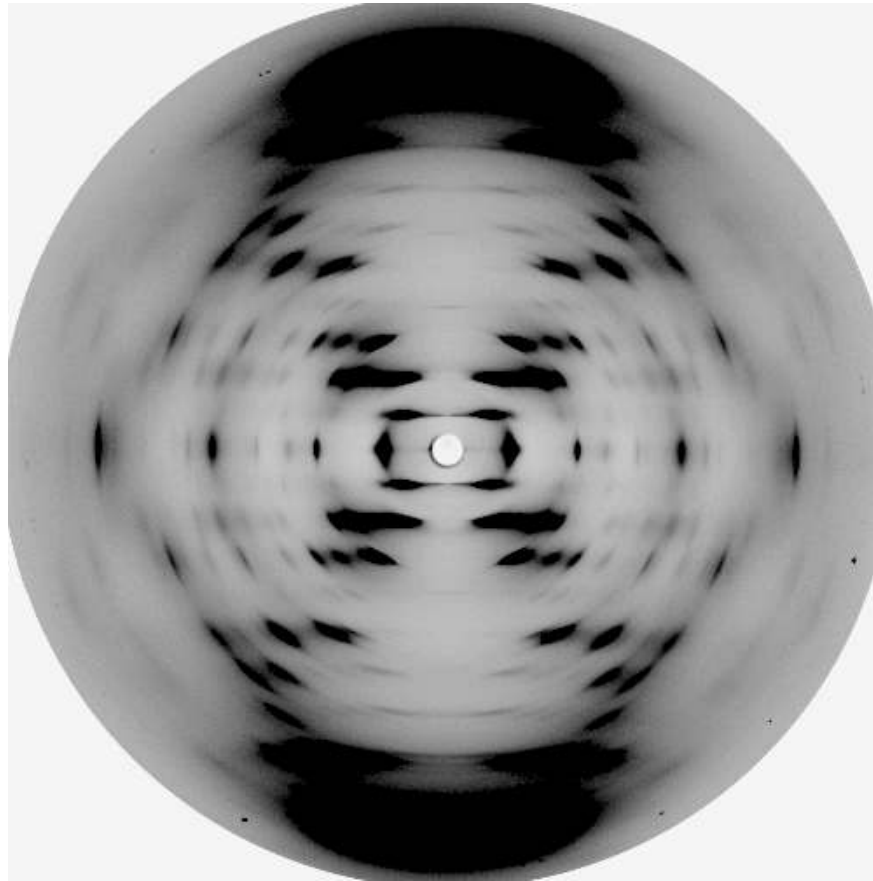

X-Ray diffraction image of DNA taken by Franklin in 1951



Maurice Wilkins



Rosalind Franklin

DNA's Structure

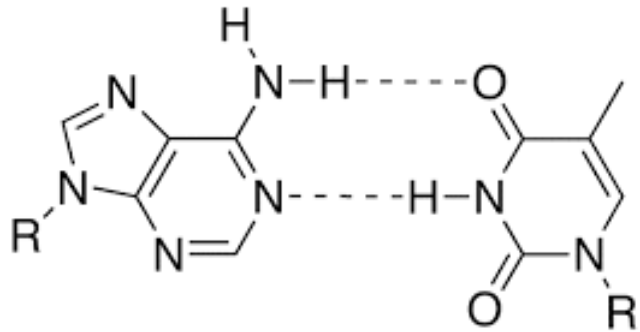

Adenine

Thymine

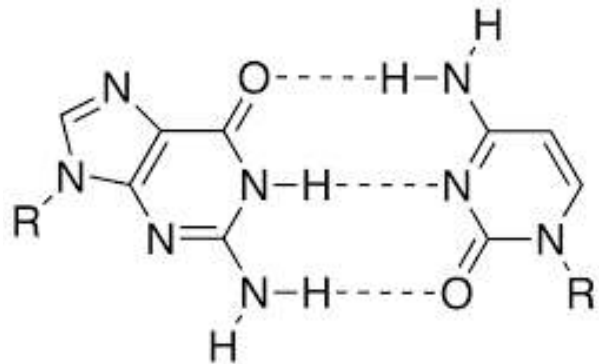

Guanine

Cytosine

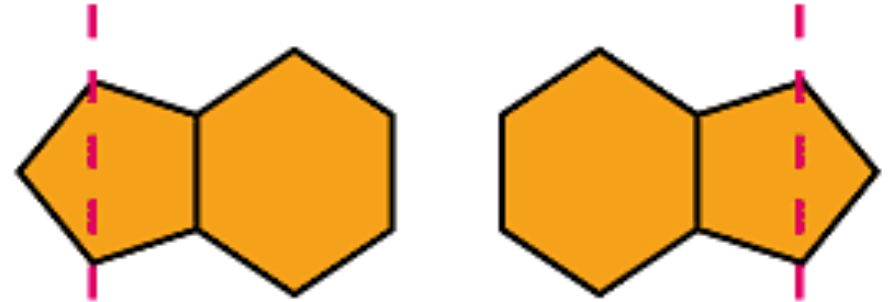

Purine + Purine = Too wide

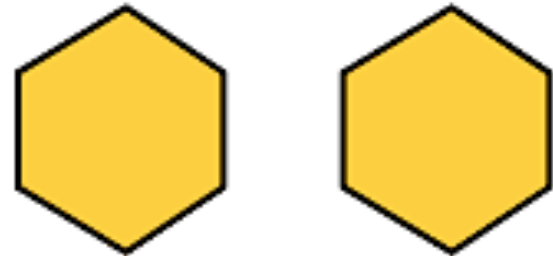

Pyrimidine + Pyrimidine = Too Narrow



Purine + Pyrimidine = Perfect Fit from X-ray data

Chargaff's rule

- Percent of adenine = percent of thymine (%A=%T)
- Percent of cytosine = percent of guanine (%C=%G)
- $A+G = T+C$ (or purines = pyrimidines)

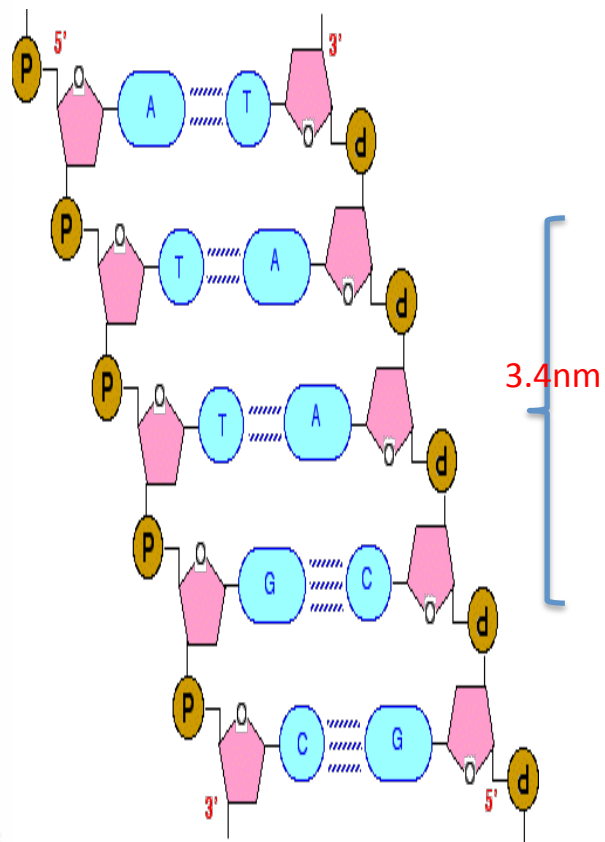
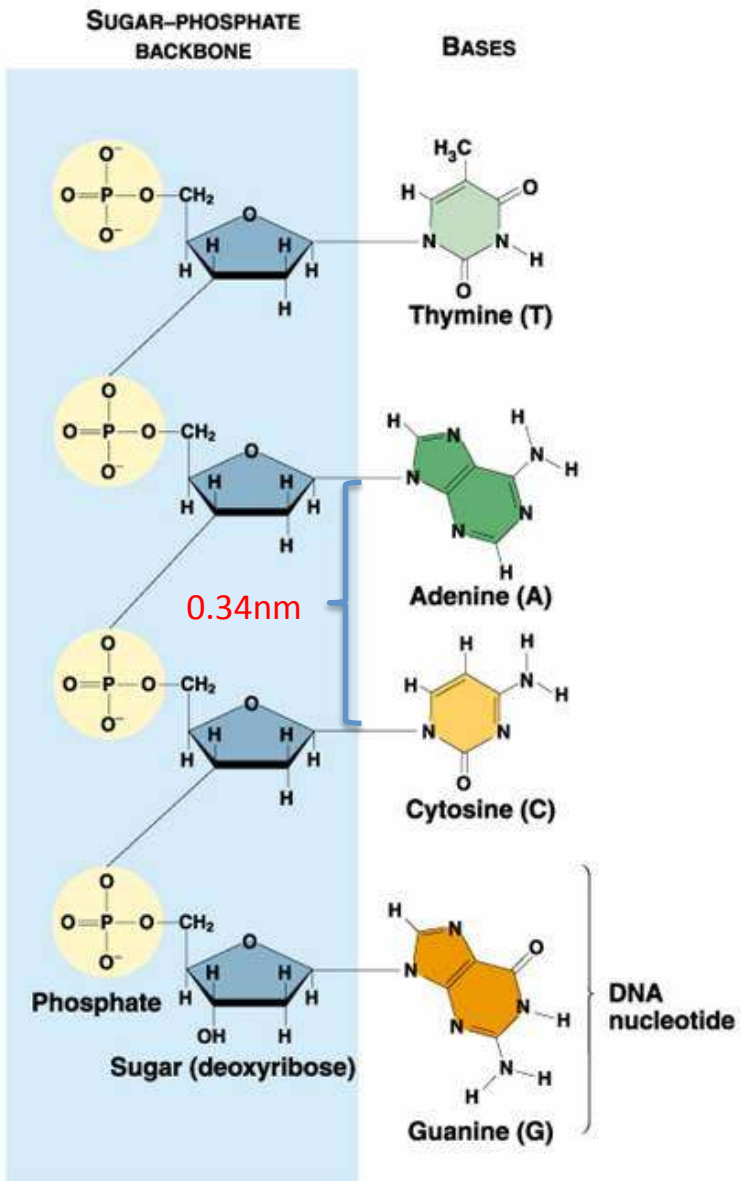

DNA Replication

- The double helix did explain how DNA copies itself
- DNA replication is a process that occurs **in all living cells**. They copy their DNA; it is the basis for **biological inheritance**. The process starts with **one** double-stranded DNA molecule and produces **two identical copies** of the molecule. Each strand of the original double-stranded DNA molecule serves as template for the production of the complementary strand. This process is referred to as **semiconservative replication**.

Replication

Before a cell divides, the DNA strands unwind and separate

Each strand makes a new partner by adding the appropriate nucleotides

The result is that there are now two double-stranded DNA molecules in the nucleus

So that when the cell divides, each nucleus contains identical DNA

This process is called **replication**

The strands
separate

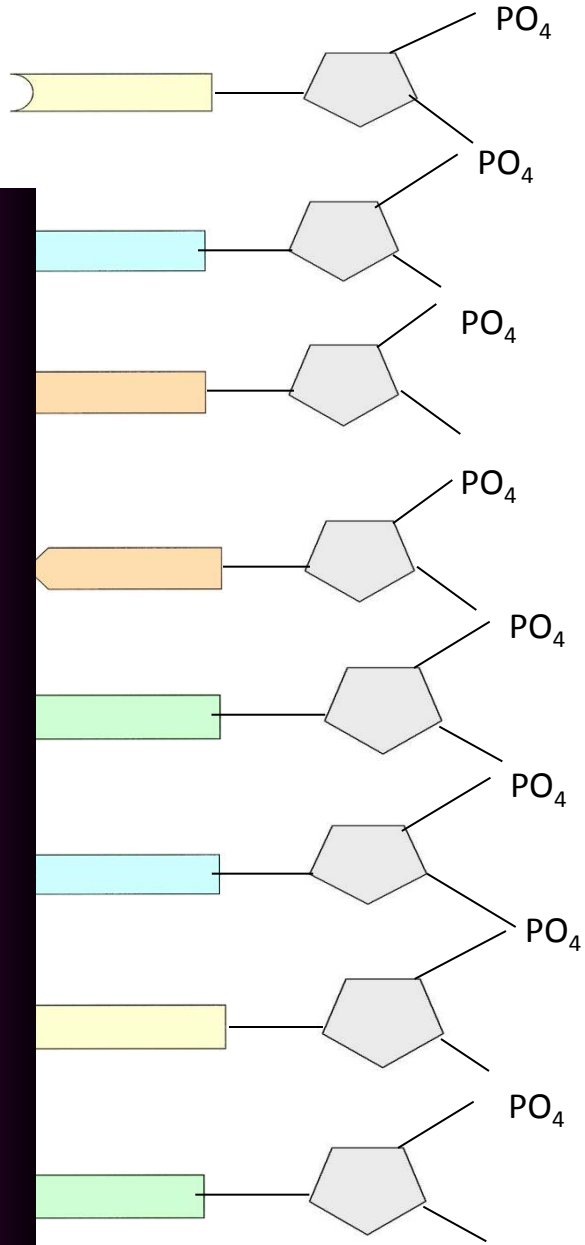
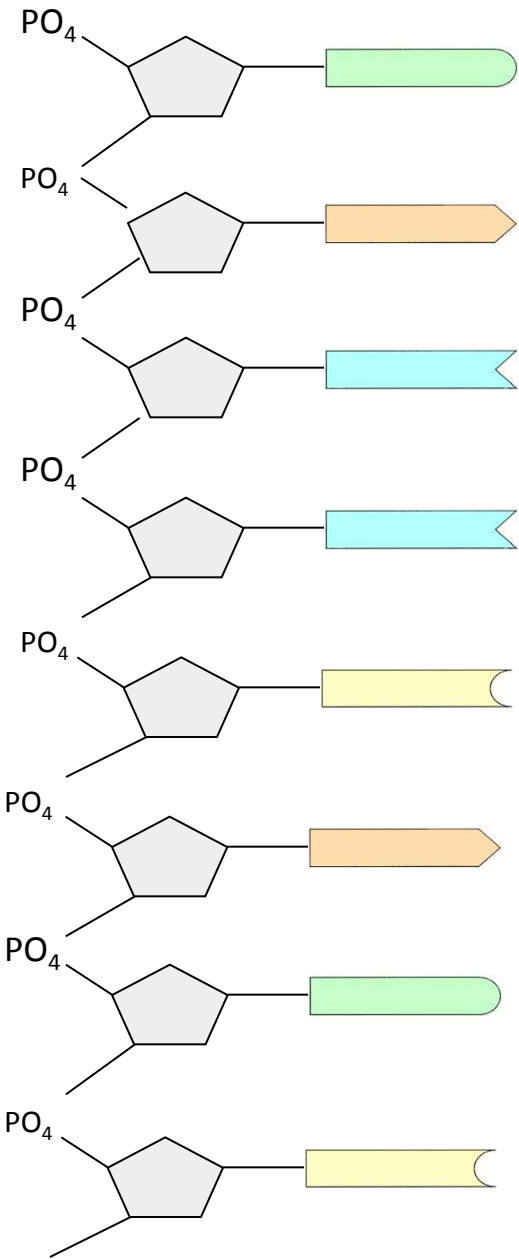

Each strand builds up its partner by adding the appropriate nucleotides

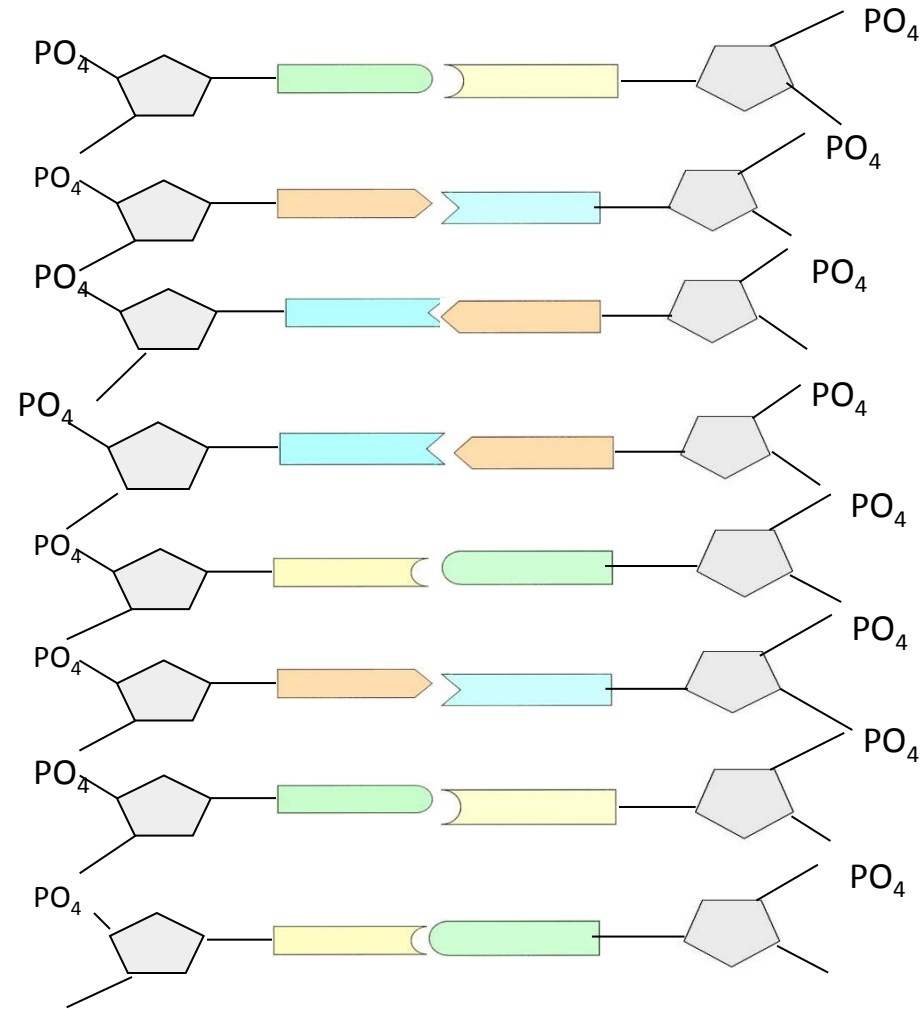
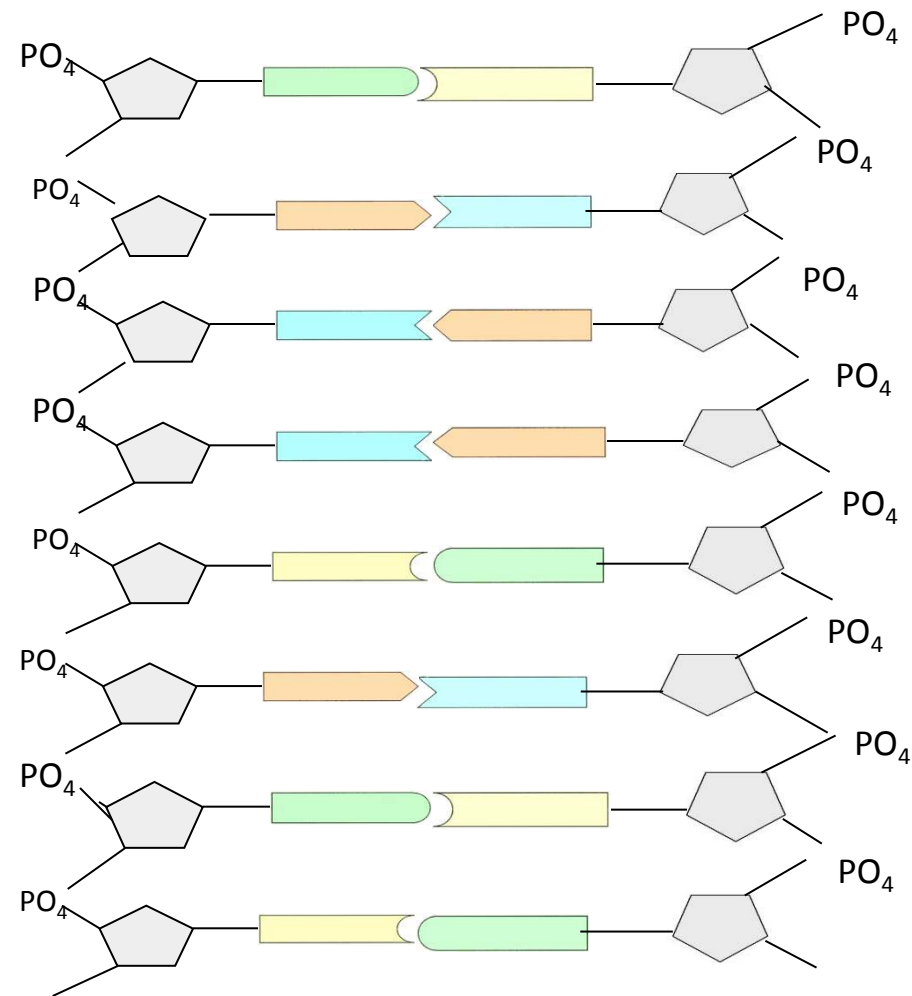

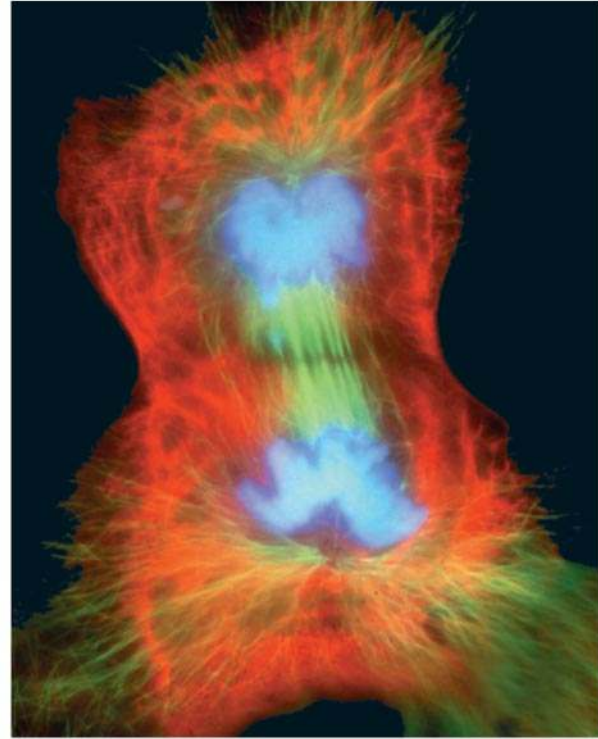
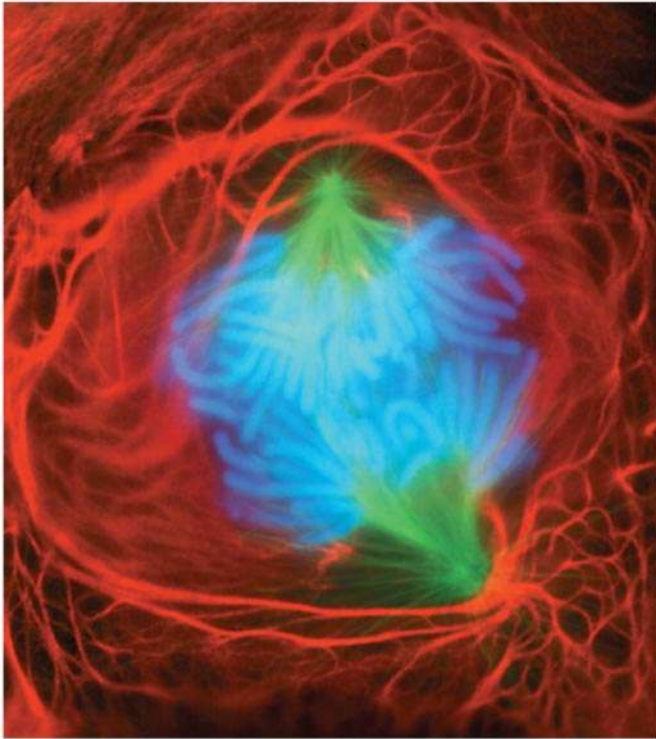

Copyright © 2008 Pearson Education, Inc., publishing as Pearson Benjamin Cummings.

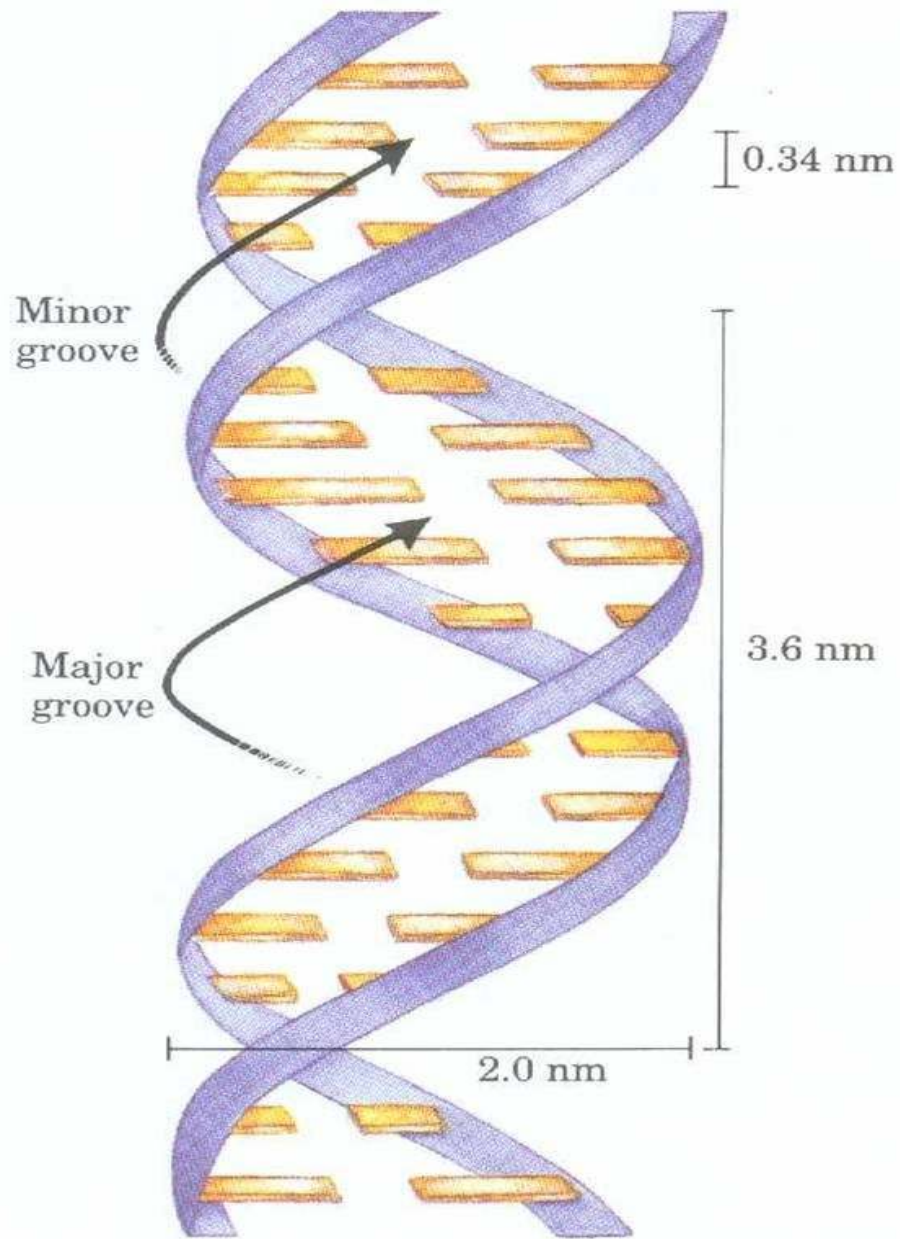

(a)

Forms of DNA

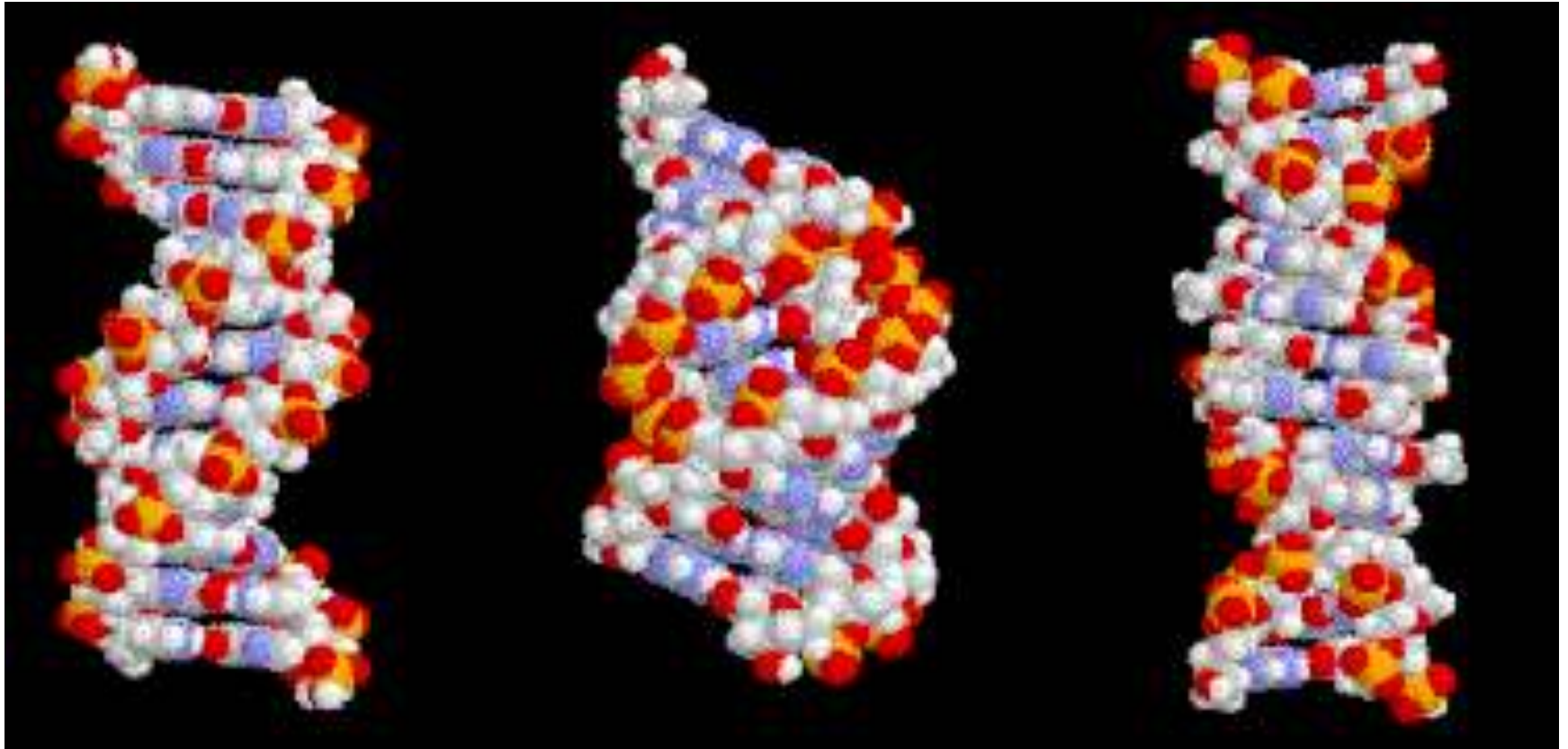

	B	A	Z
helix sense	RH	RH	LH
bp per turn	10	11	12
vertical rise per bp	3.4	2.56	3.7 Angstroms
rotation per bp	+36	+33	-30 degrees
helical diameter	19	23	18 Angstroms

- Genes control protein production indirectly
- DNA is transcribed into RNA then translated into a protein
- An organism's **genome** is its entire set of genetic instructions

CENTRAL DOGMA



Properties of RNA

- Single stranded
- More flexible → 3D molecular shape
- Ribose sugar
- Uracil in place of Thymine
- RNA is short, only 1 gene long, where DNA is very long and contains many genes
- Act as enzymes: Ribozymes

- Classes: two
 - Informational: mRNA
 - Functional: tRNA and rRNA
 - Small nuclear in Eukaryotes for modification of rRNA as part of spliceosome

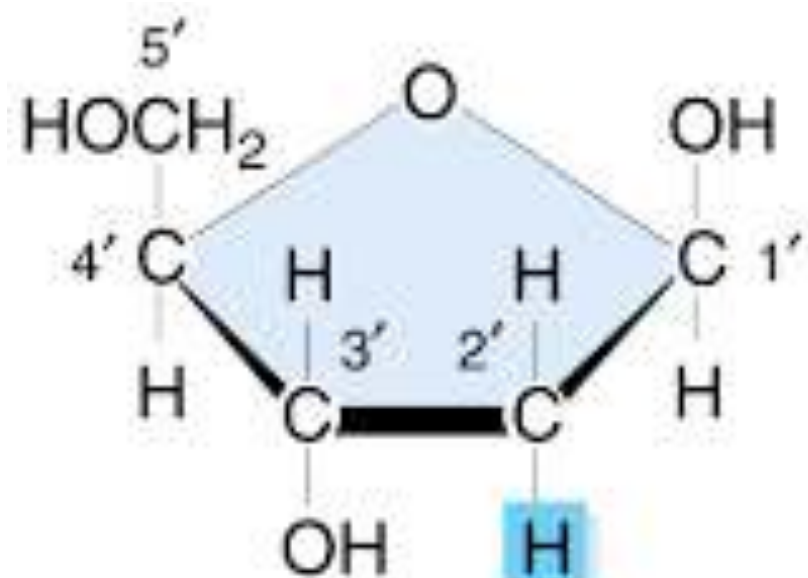

Deoxyribose

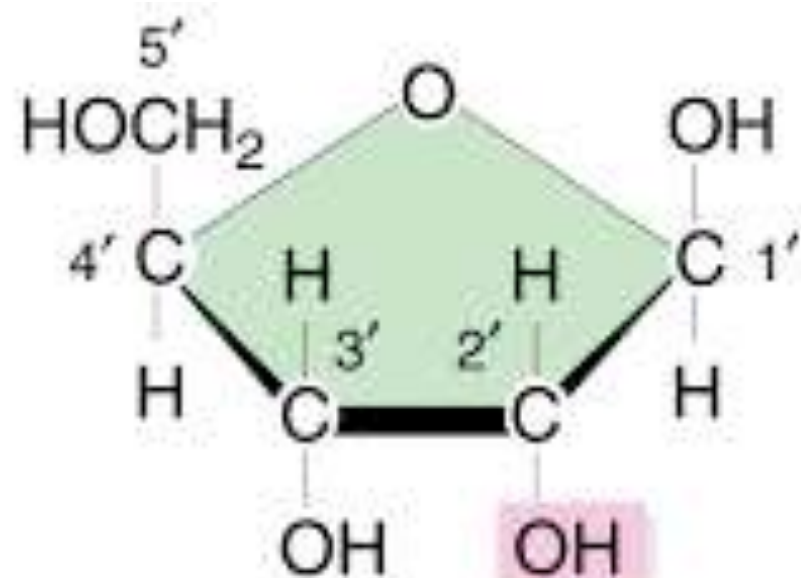

Ribose

Basic steps in transcription

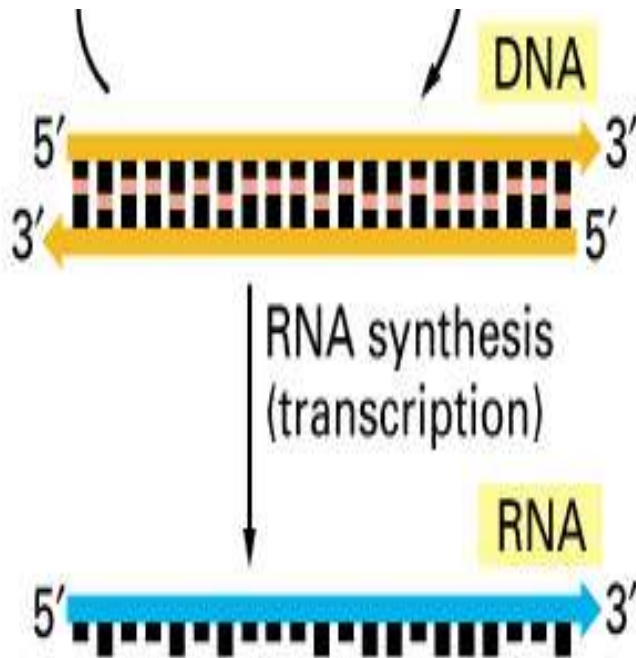

- DNA and RNA function is based on two principles
 - Complementarity of bases
 - Sequence specific recognition of proteins
- Local separation of strand
- Any one strand serves as template for a particular gene
- Growth is from 5' to 3' and nt added to 3'
- Stages of transcription:
 - Initiation
 - Elongation
 - Termination

Transcription and Translation

(A) EUKARYOTES

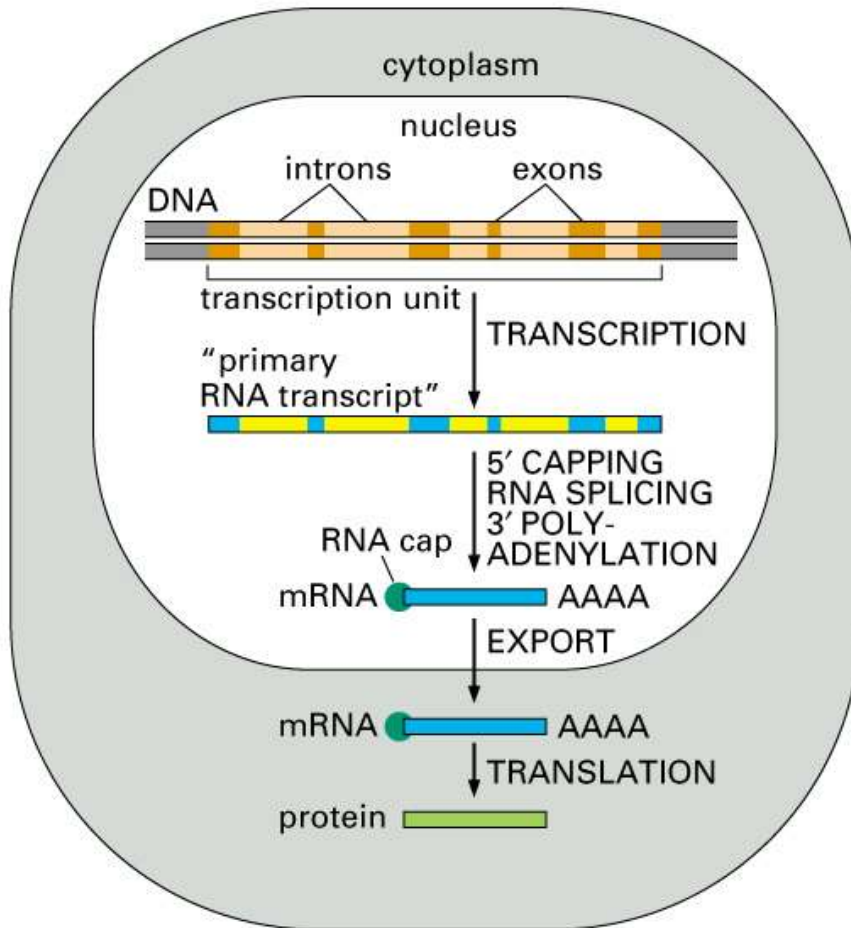

(B) PROCARYOTES

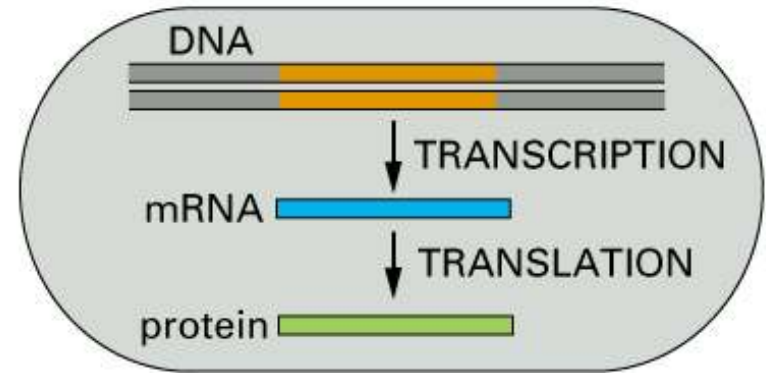
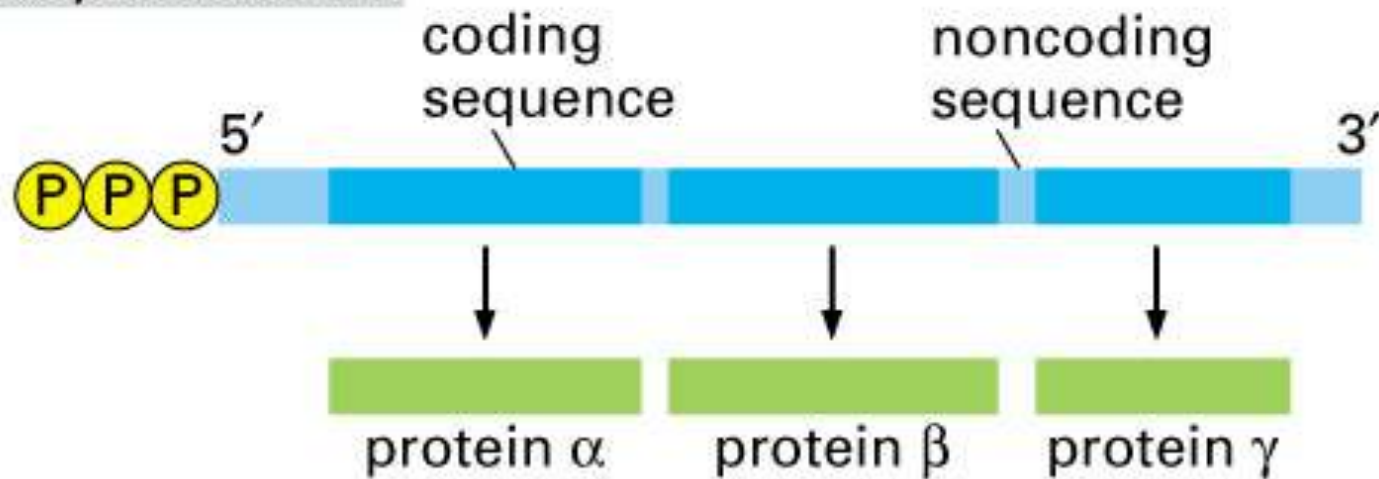
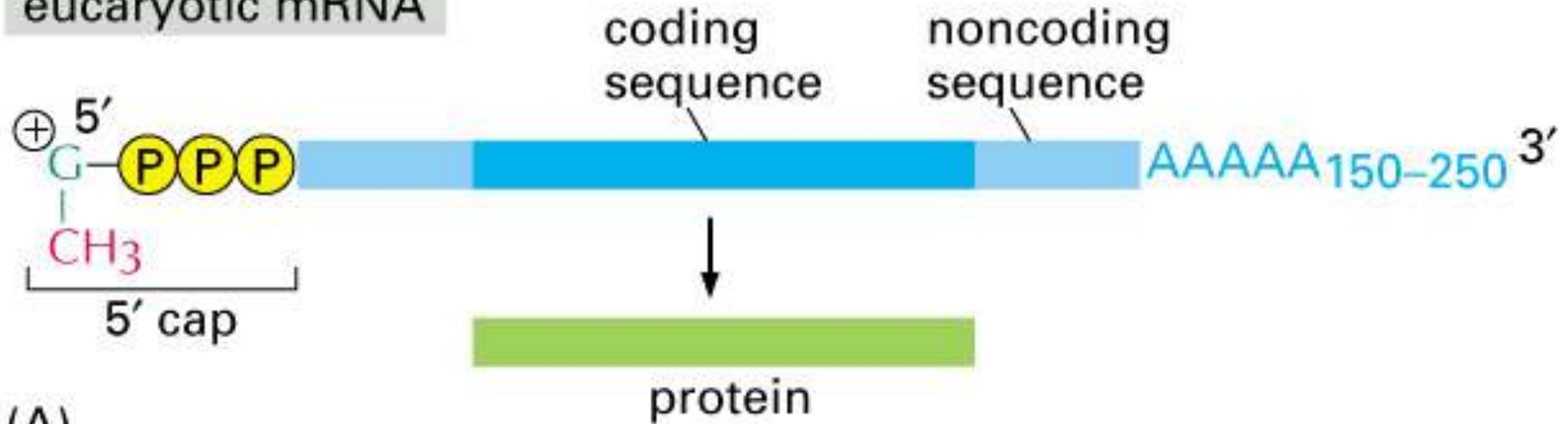

Figure 6-21 part 2 of 2. Molecular Biology of the C

procaryotic mRNA



eucaryotic mRNA



(A)

Figure 6-22 part 1 of 2. Molecular Biology of the Cell, 4th Edition.

Different types of RNA processing

1. Splicing
2. Addition of Cap at 5' end
3. Addition of poly A tail

Function of 5' Cap

1. Facilitate export of mature mRNA from the nucleus
2. Help protect mRNA from degradation
3. Help ribosome attach to 5' end of mRNA once mRNA in cytoplasm

Function of 3' poly A tail

1. Stability
2. Termination of transcription

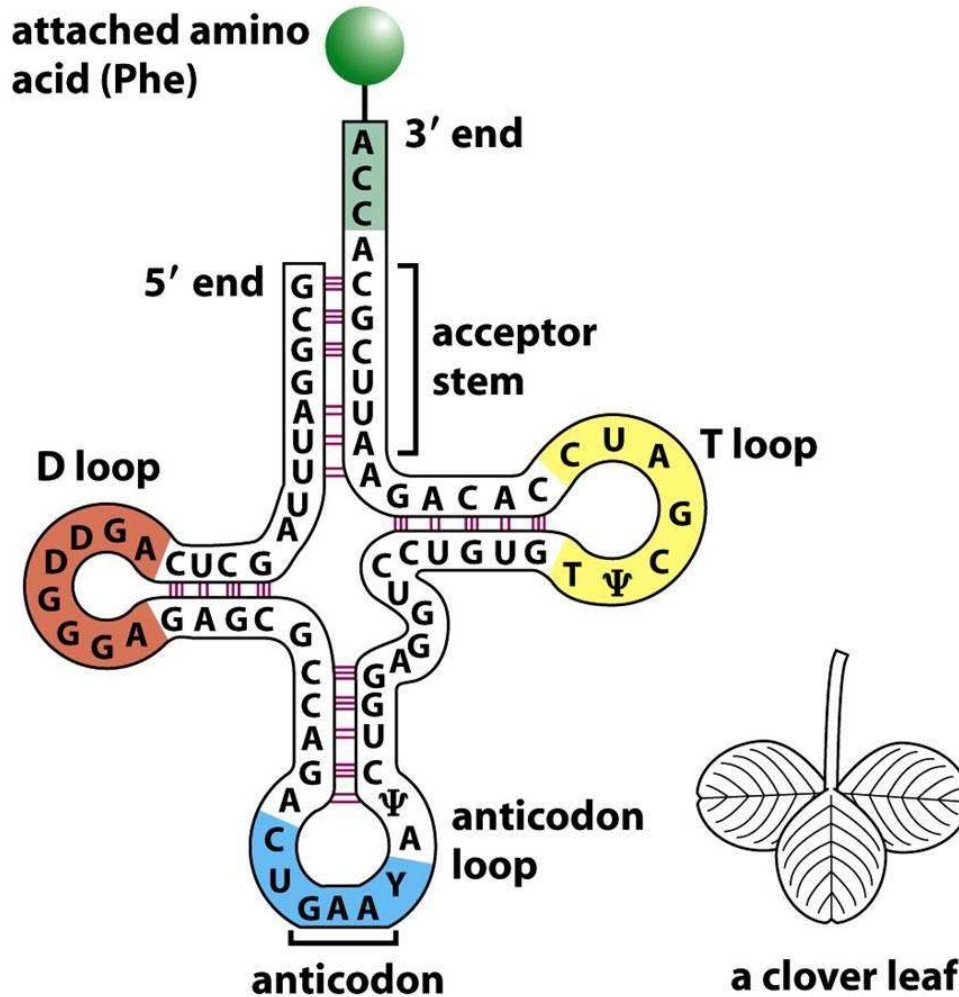

- anticodon- 3' to 5' sequence that matches the complementary 5' to 3' sequence (codon) on the mRNA
- Acceptor arm - Amino acid code on 3' end
- T and D loops – provide structure for interface with aminoacyl-tRNA synthetase

DNA Transcription

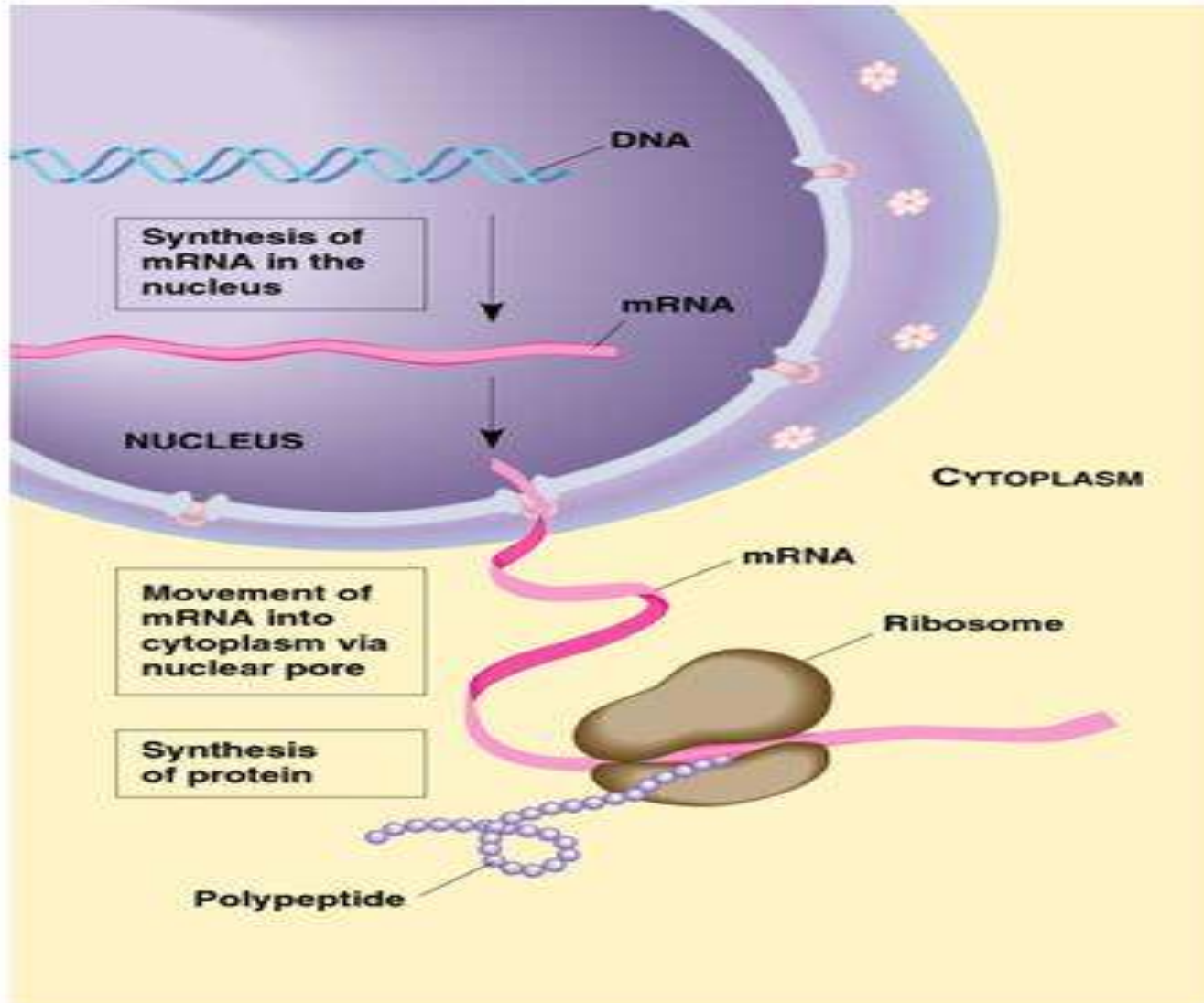

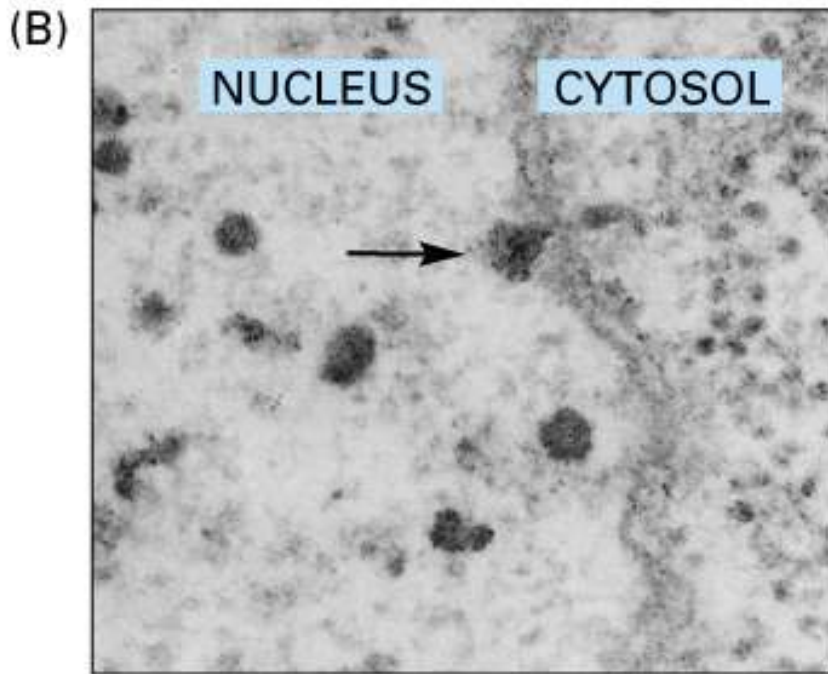
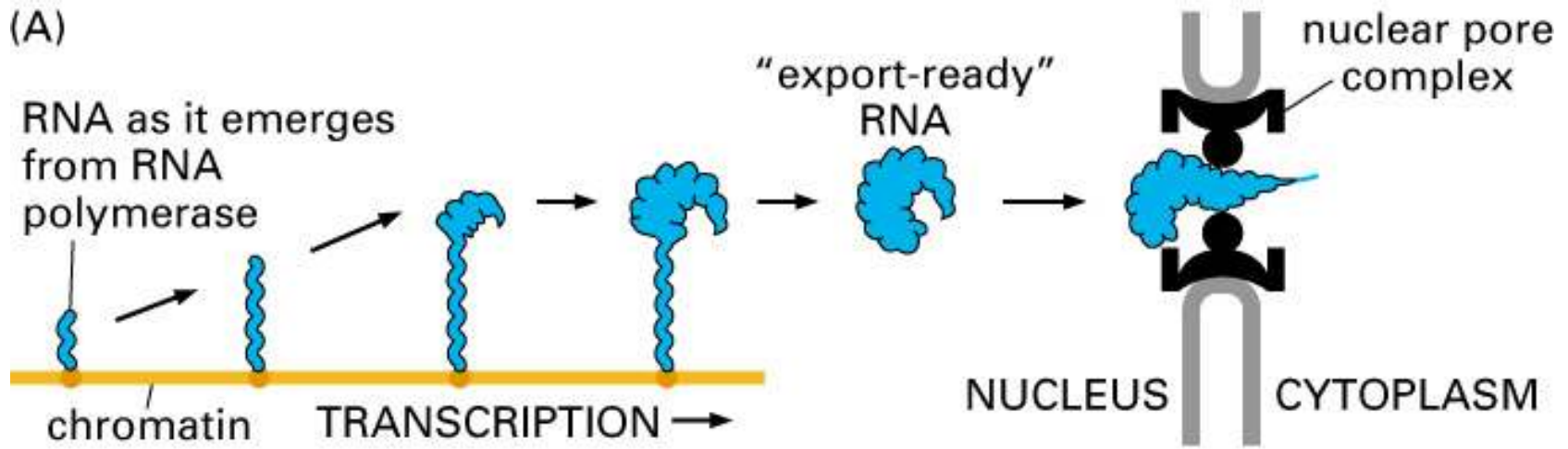

Only very "select" RNAs can be transported out of the nucleus

Figure 6-39. Molecular Biology of the Cell, 4th Edition.

Fig. 18-6a

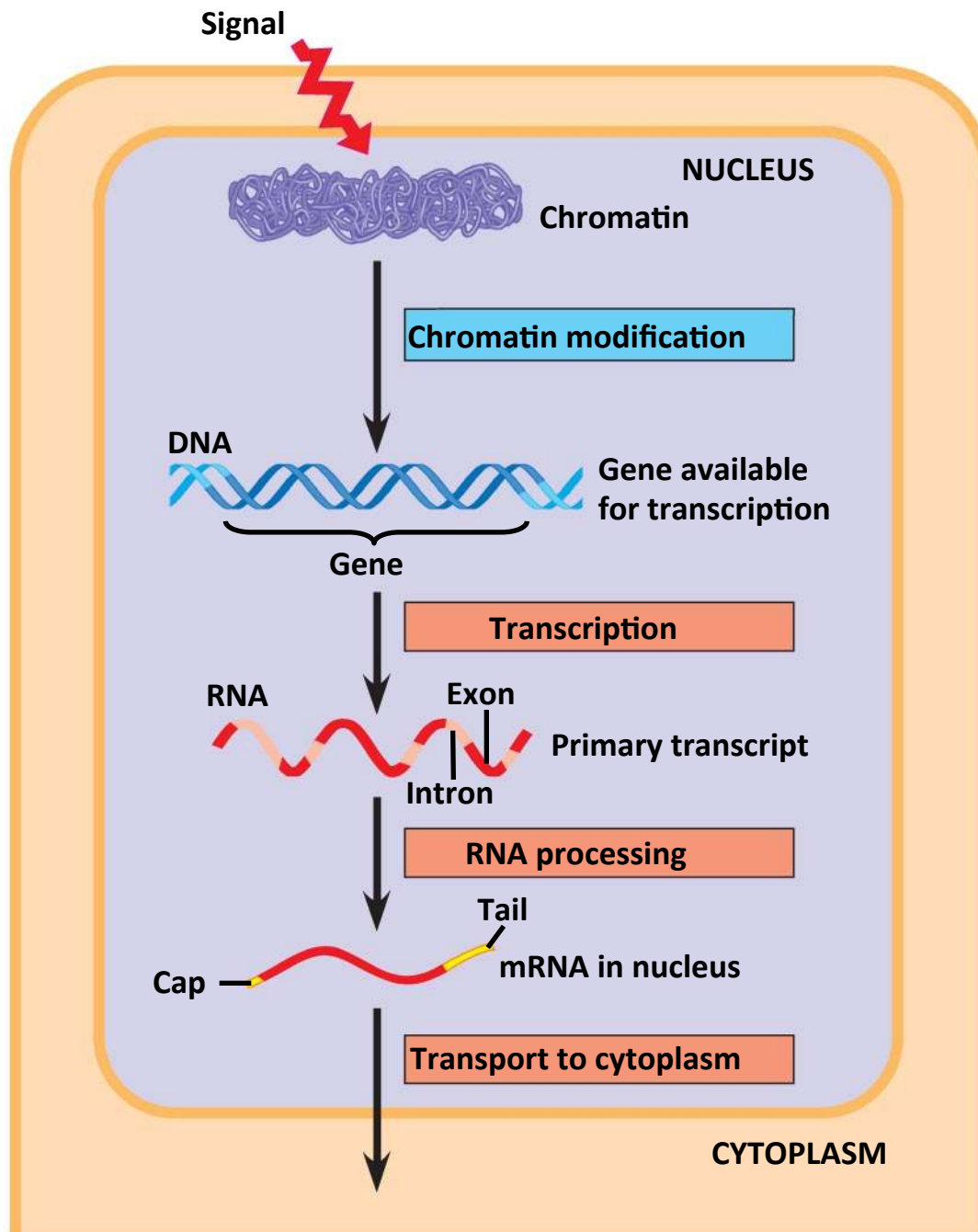
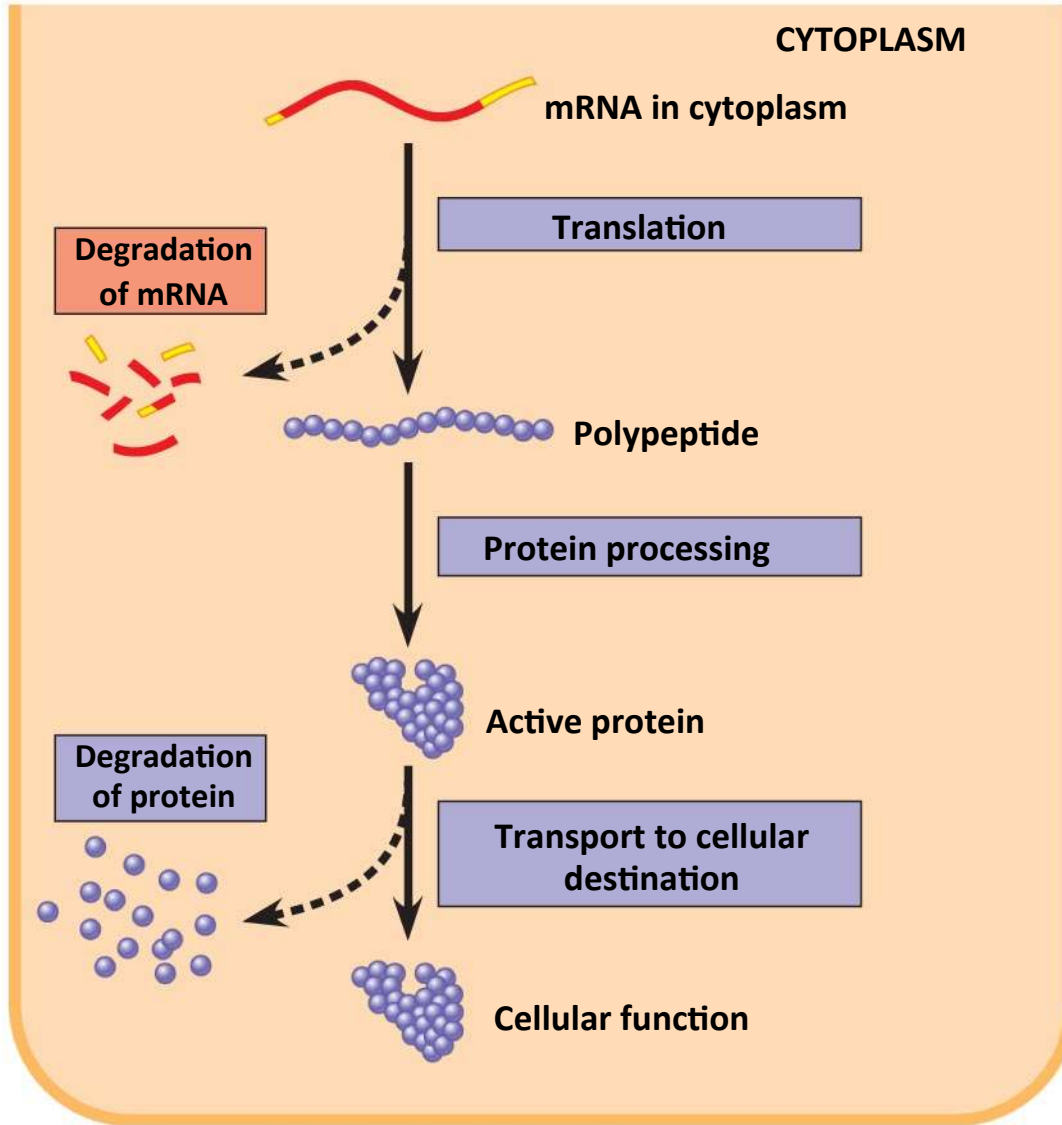
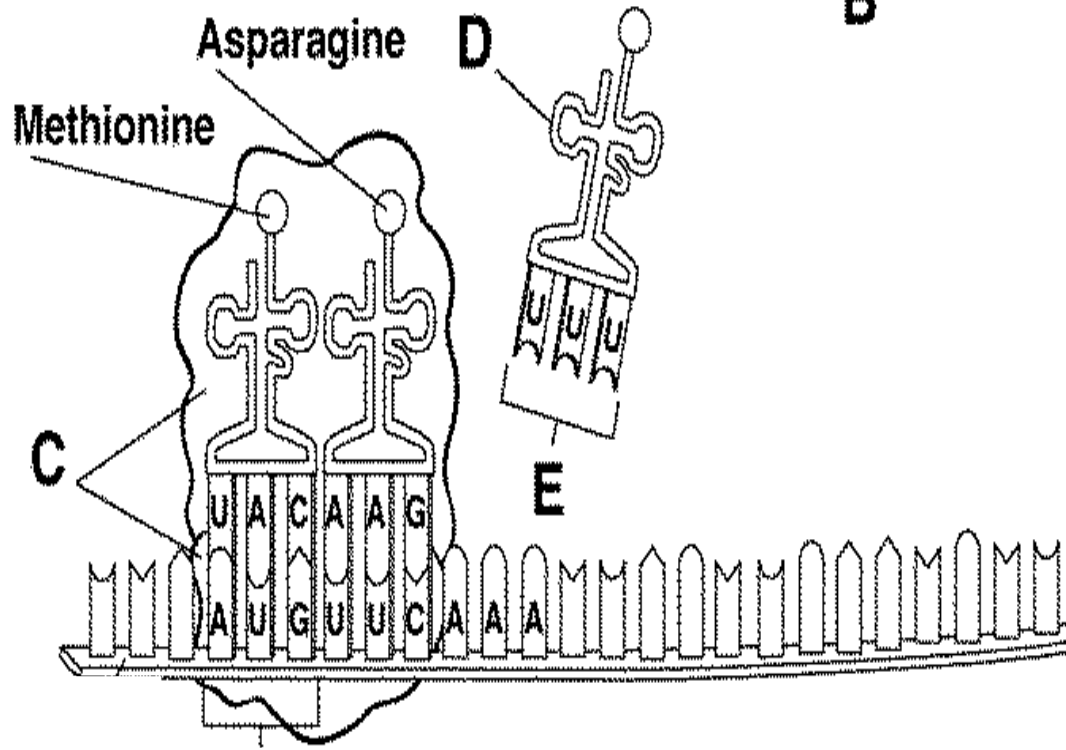
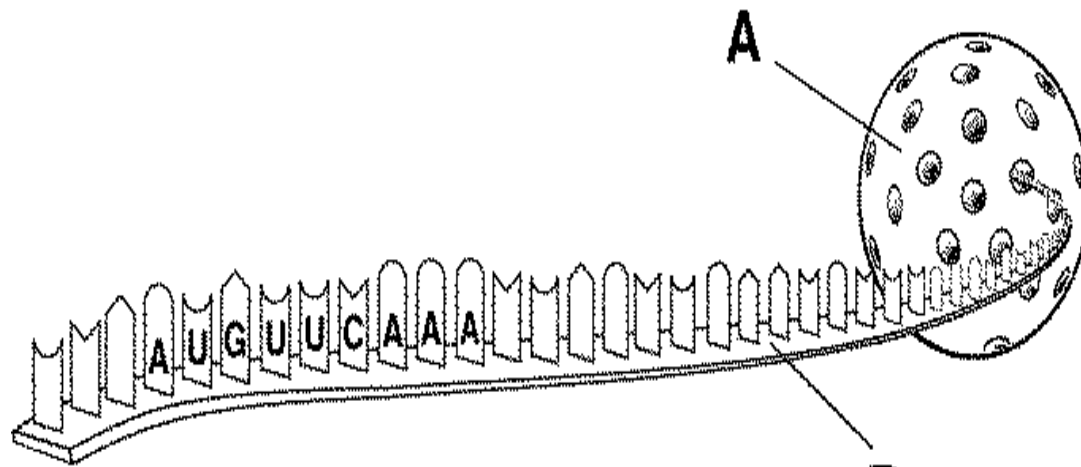

Fig. 18-6b



(1961) Watson & Crick proposed...

- ...DNA controlled cell function by serving as a template for PROTEIN structure.
- 3 Nucleotides = a triplet or CODON
(which code for a specific AMINO ACID)
- AMINO ACIDS are the building blocks of proteins.



Triplet code:

A continuous sequence of three nucleotides codes for a specific amino acid

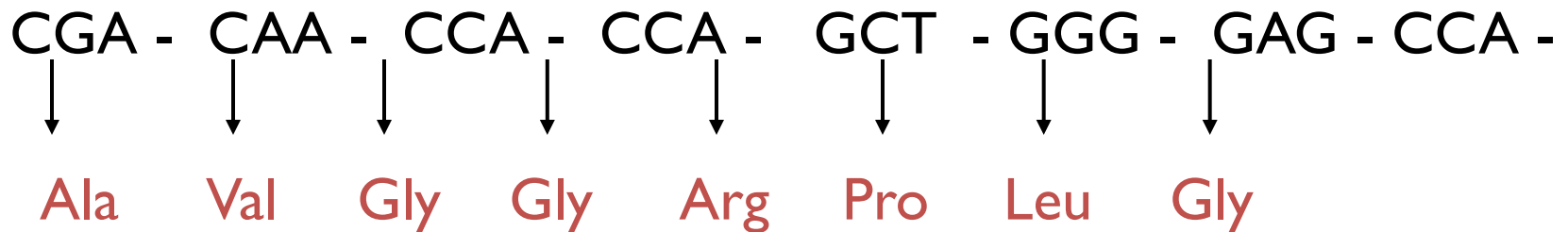

The amino acids are joined together in the correct sequence to make part of a protein

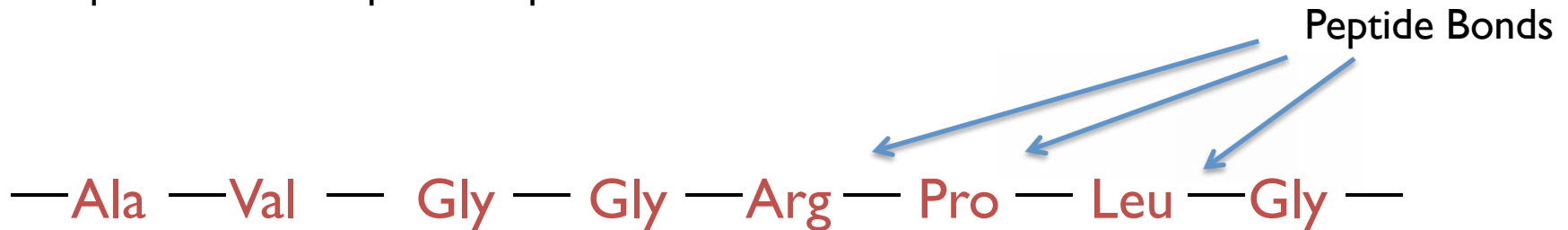

Genetic code is

1. Triplet
2. Non-overlapping
3. Degenerate

overlapping
code

AUU UUG UGC

codon

AUU GCU CAG

nonoverlapping
code

AUU GCU CAG

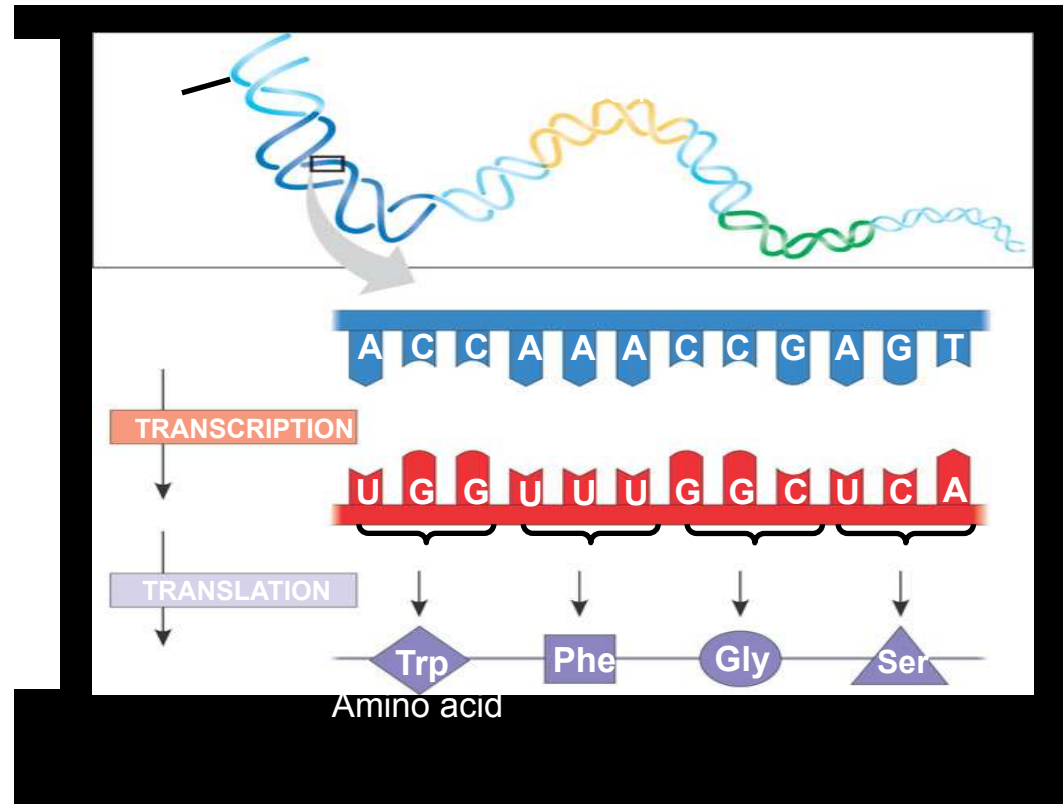

The Genetic Code

- A codon in messenger RNA is either translated into an amino acid or serves as a translational start/stop signal

		Second mRNA base					
		U	C	A	G		
First mRNA base (5' end)	U	UUU	UCU UCC UCA UCG	UAU	UGU UGC UGA UGG	U C A G	
		UUC		UAC			UGC
		UUA		UAA Stop			UGA Stop
		UUG		UAG Stop			UGG
	C	CUU	CCU CCC CCA CCG	CAU	CGU CGC CGA CGG	U C A G	
		CUC		CAC			CGC
		CUA		CAA			CGA
		CUG		CAG			CGG
	A	AUU	ACU ACC ACA ACG	AAU	AGU AGC AGA AGG	U C A G	
		AUC		AAC			AGC
		AUA		AAA			AGA
		AUG Met or start		AAG			AGG
	G	GUU	GCU GCC GCA GCG	GAU	GGU GGC GGA GGG	U C A G	
		GUC		GAC			GGC
		GUA		GAA			GGA
		GUG		GAG			GGG
		Third mRNA base (3' end)					

Proteins

Type of Protein	Function	Examples
Enzymatic proteins	Selective acceleration of chemical reactions	Digestive enzymes catalyze the hydrolysis of the polymers in food.
Structural proteins	Support	Insects and spiders use silk fibers to make their cocoons and webs, respectively. Collagen and elastin provide a fibrous framework in animal connective tissues. Keratin is the protein of hair, horns, feathers, and other skin appendages.
Storage proteins	Storage of amino acids	Ovalbumin is the protein of egg white, used as an amino acid source for the developing embryo. Casein, the protein of milk, is the major source of amino acids for baby mammals. Plants have storage proteins in their seeds.
Transport proteins	Transport of other substances	Hemoglobin, the iron-containing protein of vertebrate blood, transports oxygen from the lungs to other parts of the body. Other proteins transport molecules across cell membranes.
Hormonal proteins	Coordination of an organism's activities	Insulin, a hormone secreted by the pancreas, helps regulate the concentration of sugar in the blood of vertebrates.
Receptor proteins	Response of cell to chemical stimuli	Receptors built into the membrane of a nerve cell detect chemical signals released by other nerve cells.
Contractile and motor proteins	Movement	Actin and myosin are responsible for the movement of muscles. Other proteins are responsible for the undulations of the organelles called cilia and flagella.
Defensive proteins	Protection against disease	Antibodies combat bacteria and viruses.

Table 5.1

Structures of Proteins

Polypeptides or proteins : Are polymers of amino acid

- **Primary structure:** Peptide bonds
- **Secondary Structure:**
Hydrogen bonds between AAs at different locations,
Electrostatic forces, van der Waals forces
Types: Alpha helices and beta pleated sheets
- **Tertiary structure:** + disulphide bonds,
formed by folding
- **Quaternary structure:** weak bonds different polypeptides

Protein Folding kinetics

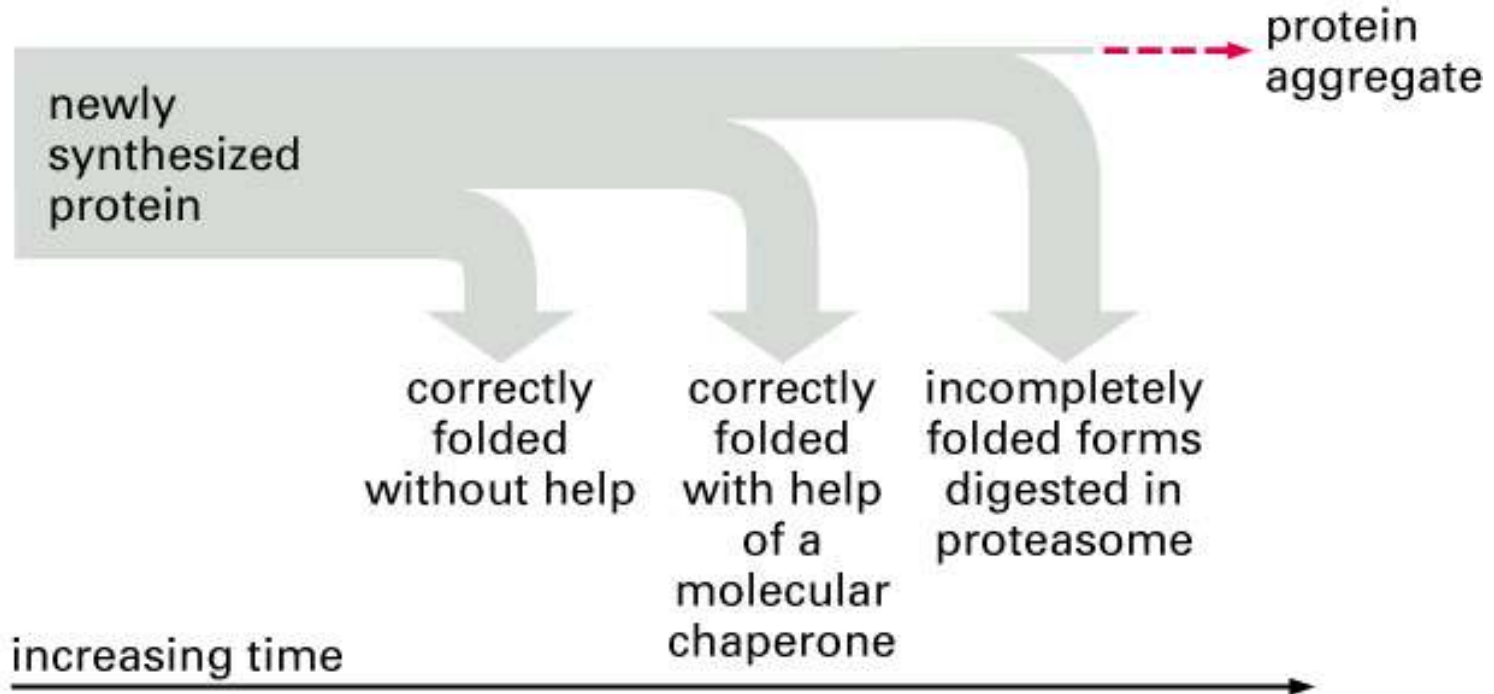

Levels of Protein Structure

—Lys—Ala—His—Gly—Lys—Lys—Val—Leu

Amino acid sequence
of polypeptide chain

PRIMARY STRUCTURE

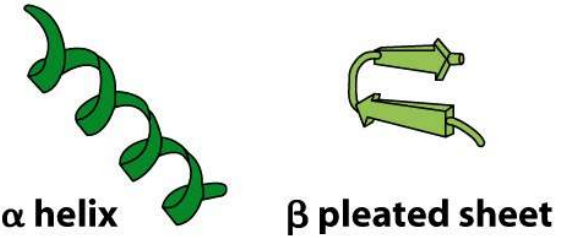

SECONDARY STRUCTURE

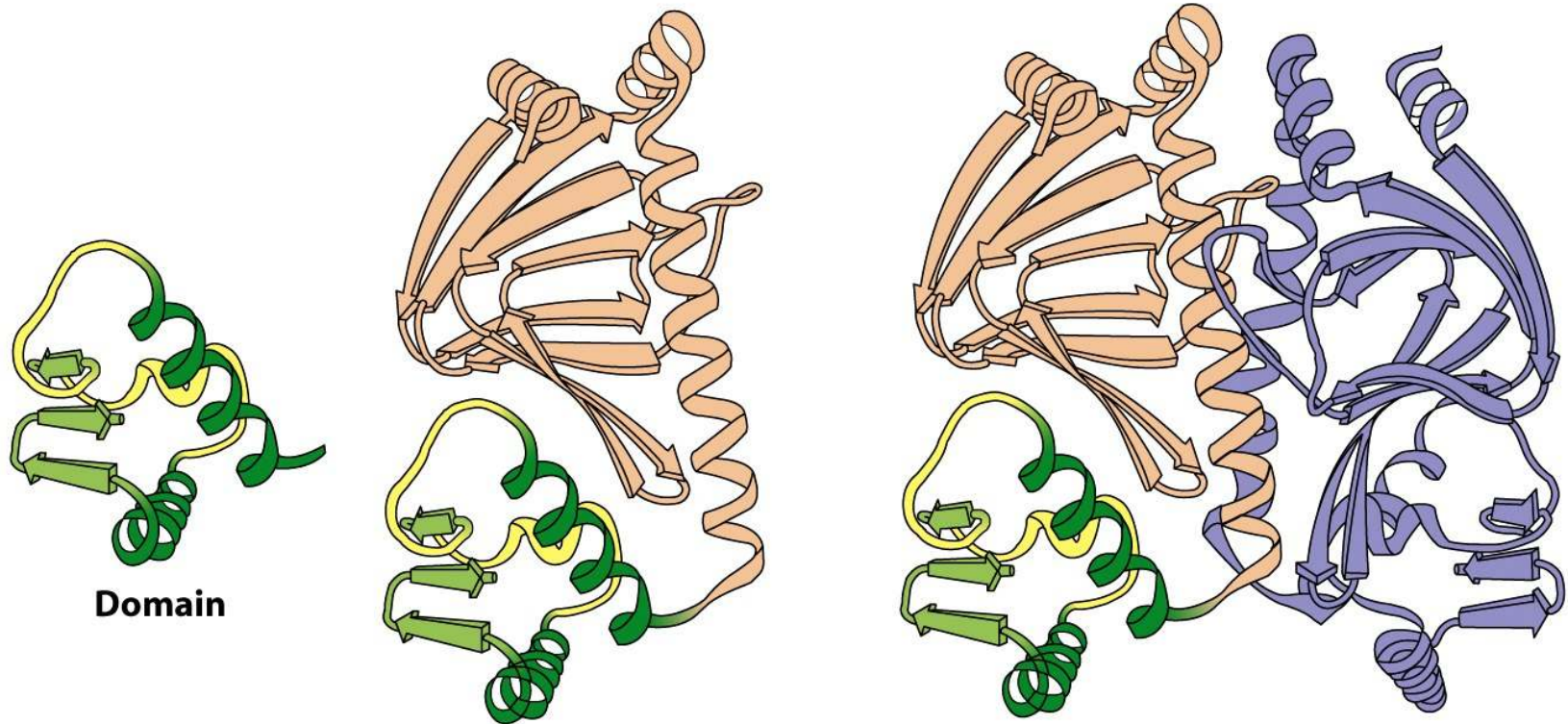

TERTIARY STRUCTURE

Dimeric protein molecule

QUATERNARY STRUCTURE

Polypeptides : Are polymers of amino acid

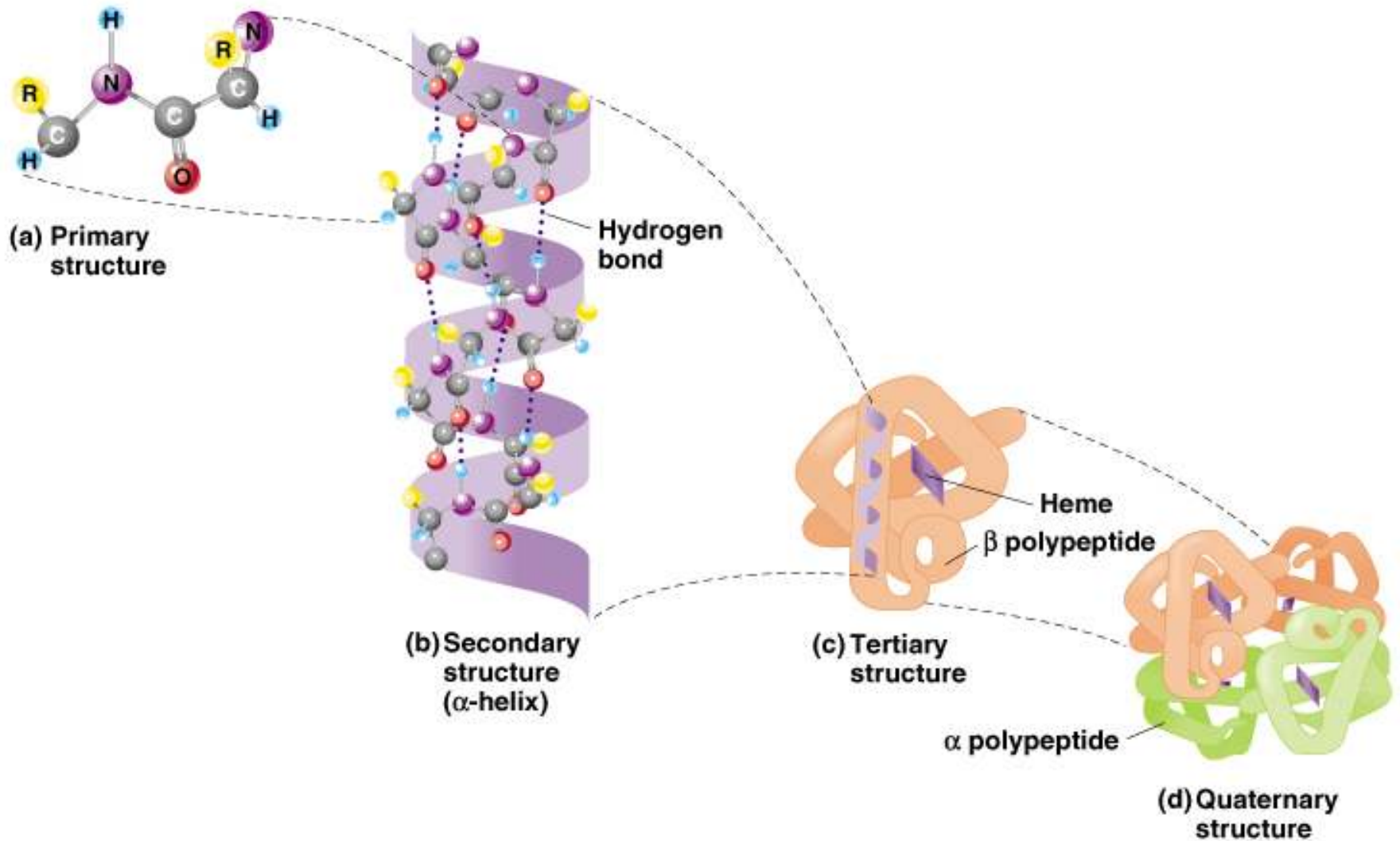

Alpha helical structure

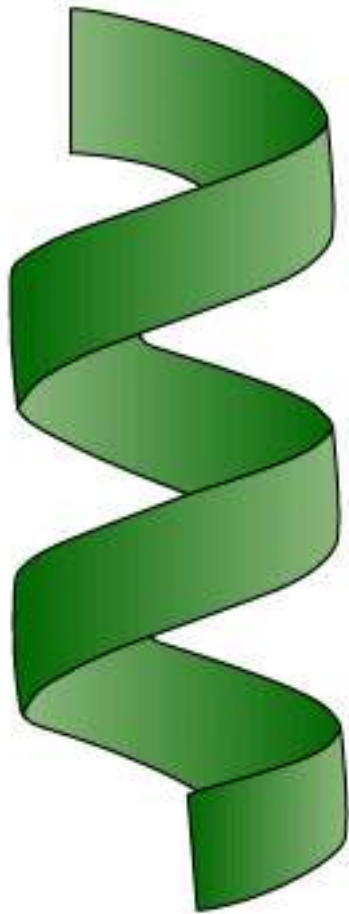

Alpha helix

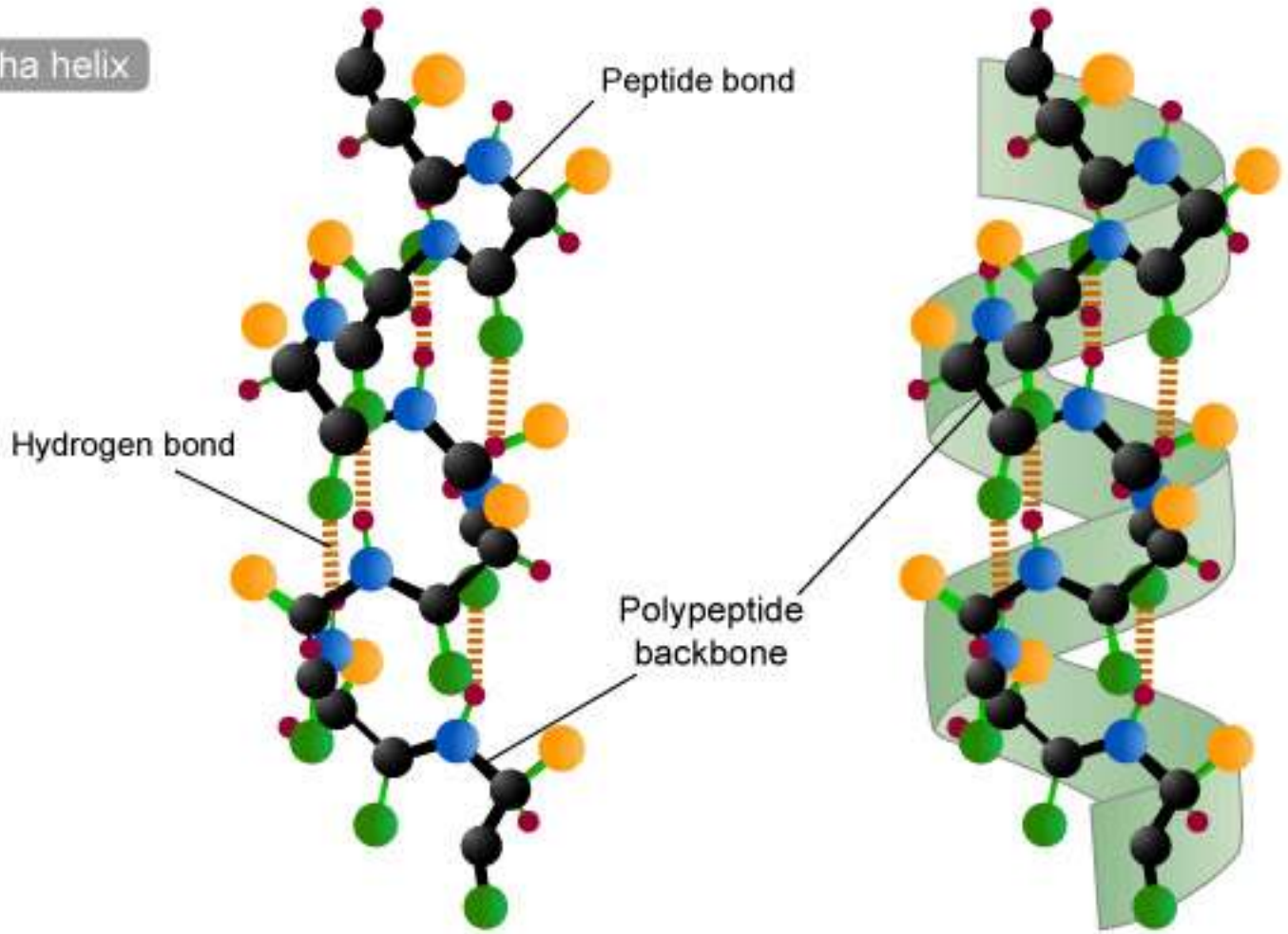

- Carbon
- Nitrogen
- R-group
- Oxygen
- Hydrogen

Beta pleated sheet structure

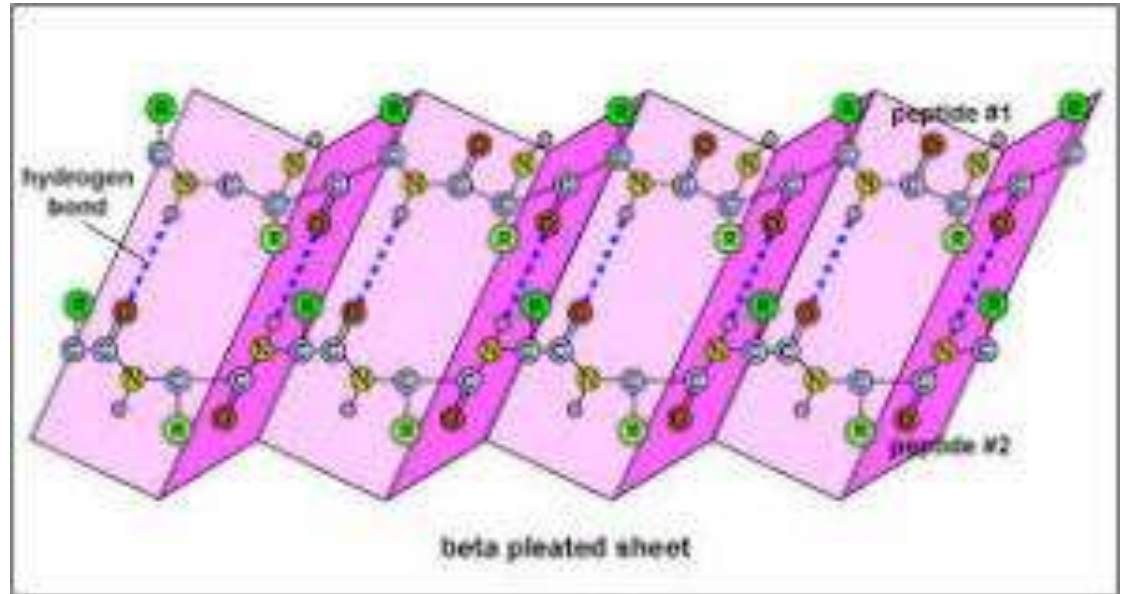
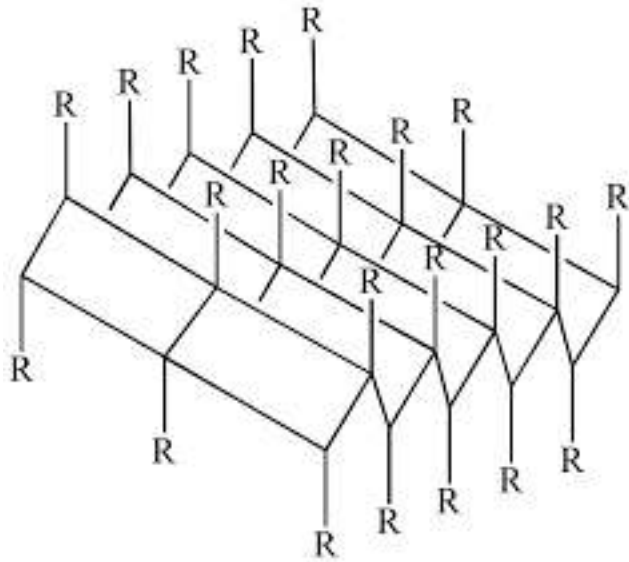

Protein Folding

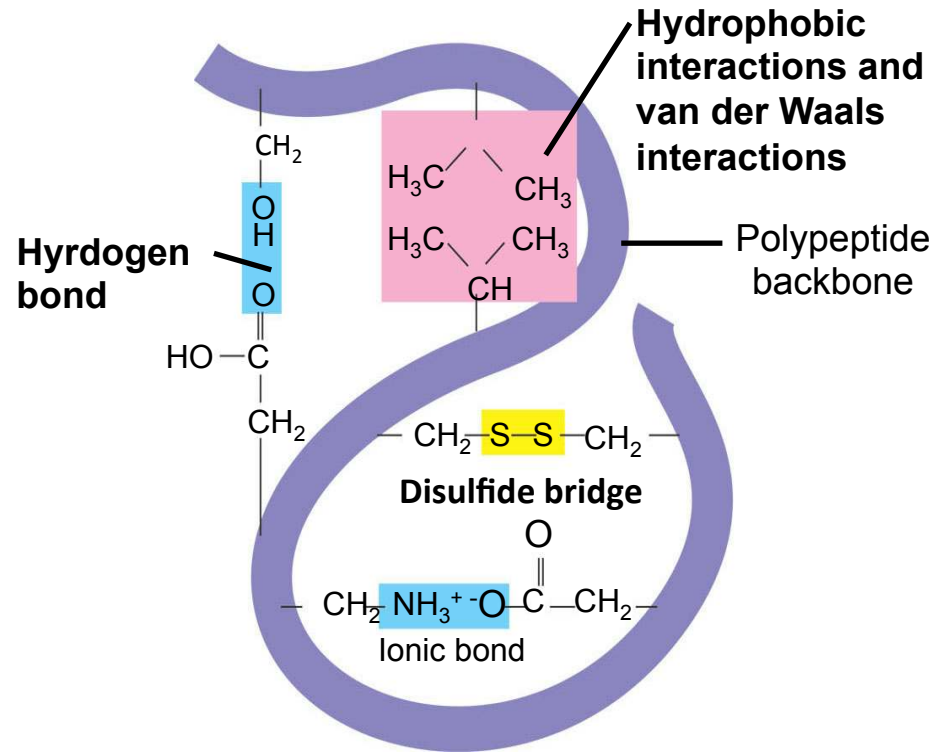
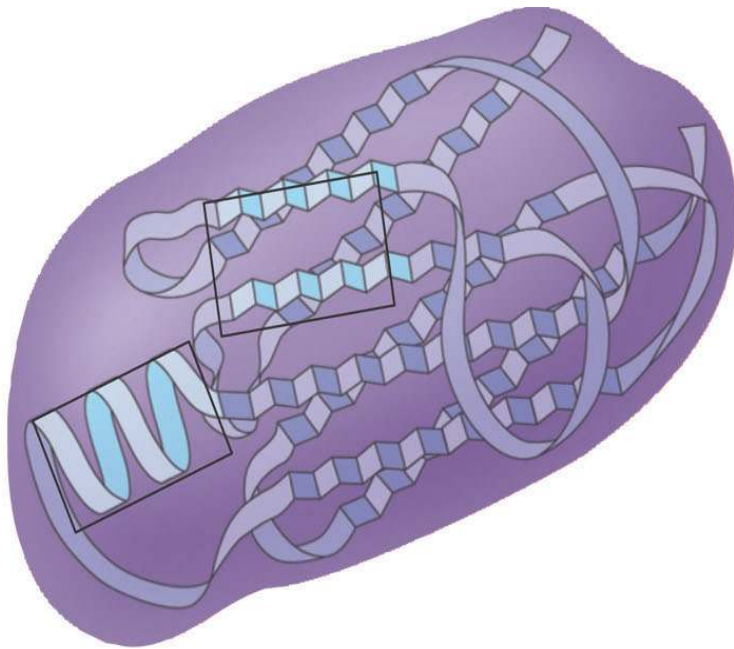

- Denaturation and Renaturation

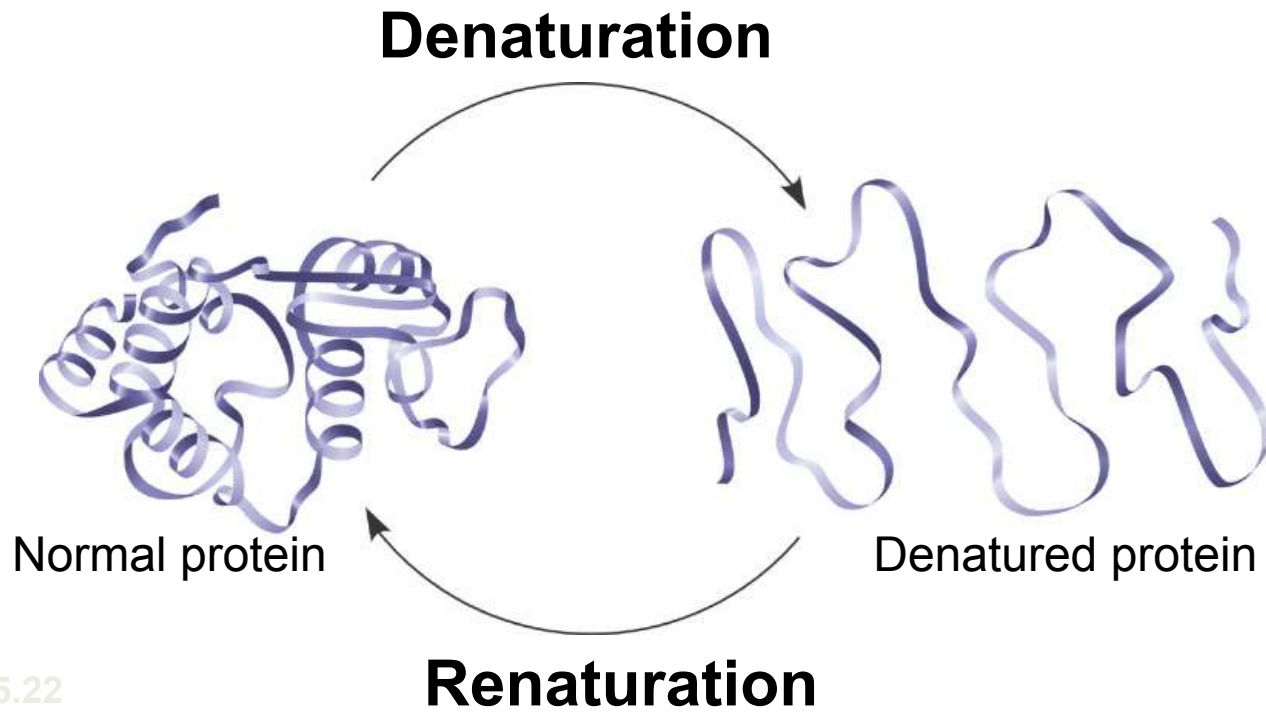
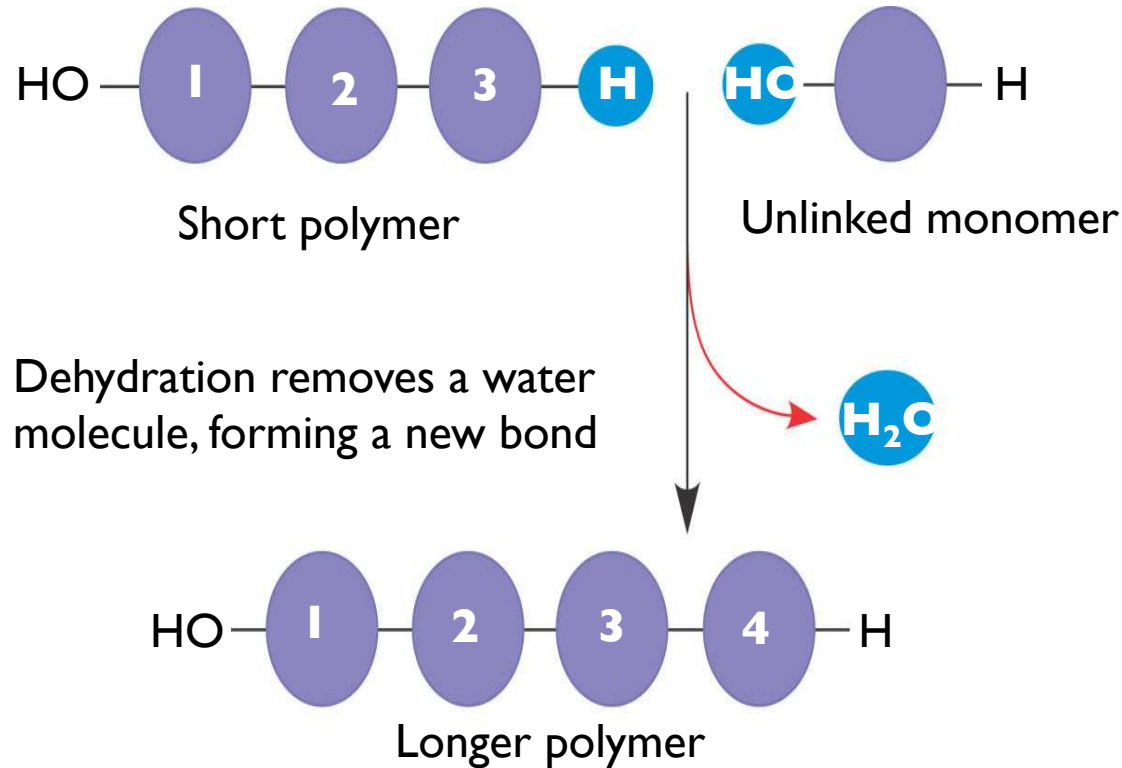

Figure 5.22

The Synthesis and Breakdown of Polymers



(a) Dehydration reaction in the synthesis of a polymer

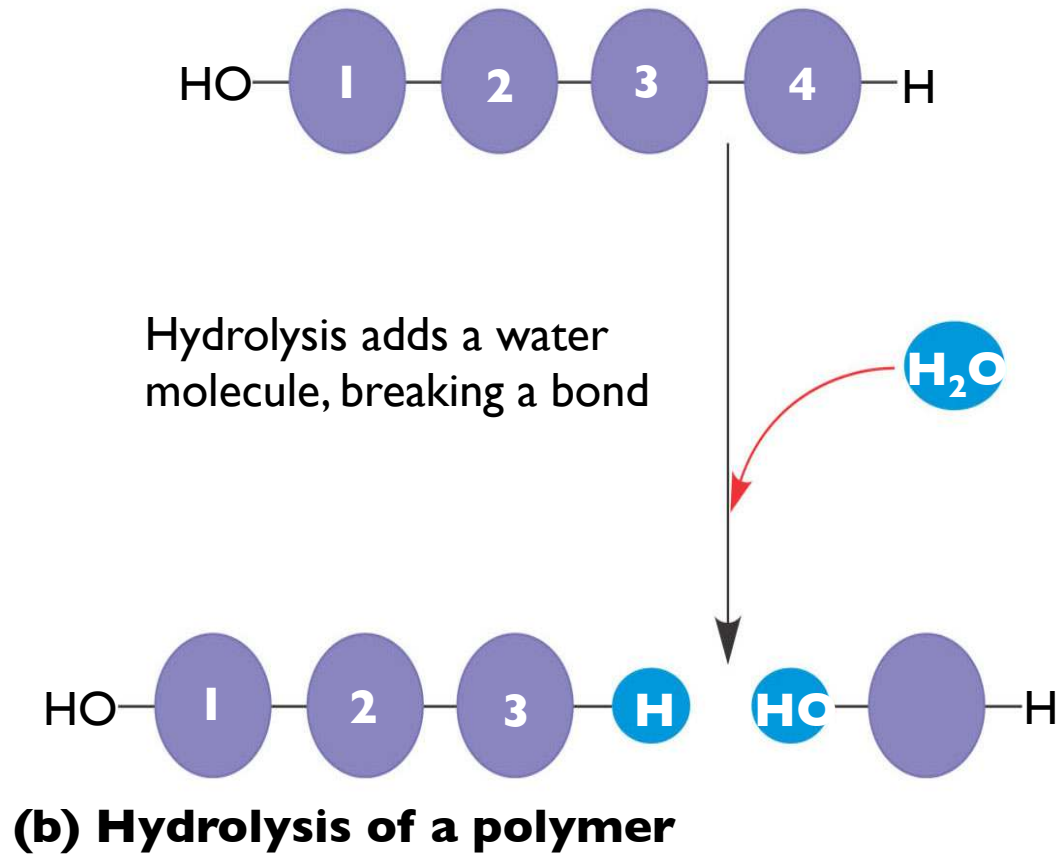

Figure 5.2B

Amino Acid Polymers

- Amino acids
 - Are linked by peptide bonds

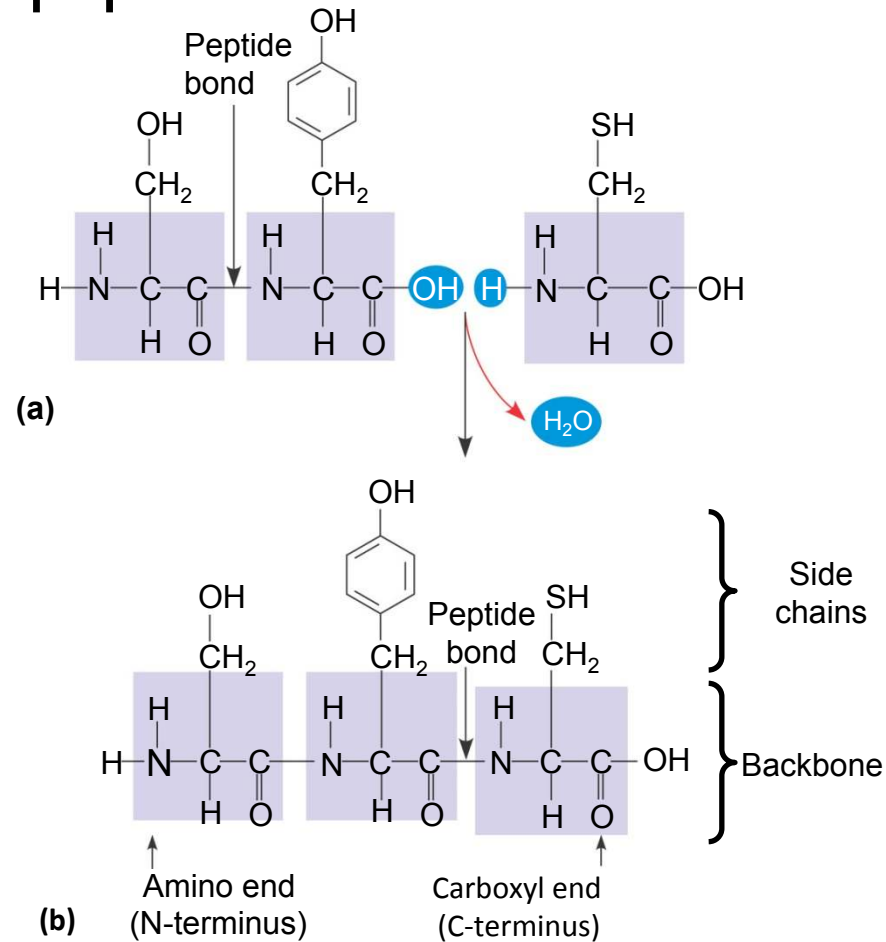

Figure 5.18